

May 27, 1958

13

PEKING

REVIEW

---

---

**INDUSTRIALIZING CHINA AT  
HIGH SPEED**

*Renmin Ribao* discusses how China is expanding industry in accordance with the principle of building more, faster, better and more economically (p. 6).

**Korea: Two Worlds**

A first-hand report from Pyongyang on the contrast between life in the Korean Democratic People's Republic and South Korea (p. 8).

**China's Monetary System**

An explanation of the outstanding features of New China's monetary system (p. 12).

**New Farm Implements**

How the introduction of new and improved tools is ushering in a technical revolution in the countryside (p. 10).

**LEBANESE FIGHT EISENHOWER DOCTRINE,  
THE FASCIST MENACE IN FRANCE**

---

---

A WEEKLY MAGAZINE OF CHINESE NEWS AND VIEWS

北  
京  
周  
報

SELECTED PLAYS OF



KUAN HAN-CHING

JUST OFF THE PRESS

A "BIG" BOOK OF 1958

This June, lovers of literature throughout the world are to mark the 700th anniversary of Kuan Han-ching, the great Chinese dramatist of the 13th century, the golden age of Chinese drama. The eight plays included in this book are selected with an eye to showing the remarkable range of this master of stagecraft, who was equally at home with tragedy and comedy, high life and low, humour and poetry.

Illustrated with traditional wood-block prints and facsimiles of early Chinese editions.

238 pp.

Published by:

FOREIGN LANGUAGES PRESS

Pai Wan Chuang, Peking (37), China

Distributed by:

GUOZI SHUDIAN

38 Suchou Hutung, Peking, China

*Read*

## CHINESE LITERATURE

a bi-monthly magazine in English

For contemporary Chinese writing, selections from classical poetry and prose, literary criticism, information about Chinese writers and artists, and beautiful art reproductions

CHINESE LITERATURE No. 4, 1958 will bring you:

*On the Tibetan Highland*, excerpts from the novel, by **Hsu Huai-chung**

*Rebirth of the Goddesses and Nirvana of the Feng and Huang*,  
poems written by **Kuo Mo-jo** in 1919 and 1920

*The Peacock Maiden*, a folk tale

*From My Notebook* by **Tu Peng-cheng**

*Indian Literature in China* by Chi Hsien-lin

*Cheng Yen-chiu, a Great Exponent of Peking Opera* by Wen Shih-ching

*Chinese Book Illustrations* by Wang Ching-hsien and Ho Yung

Order your copy of CHINESE LITERATURE  
today from your bookseller or direct  
from the chief distributor in Peking:

GUOZI SHUDIAN

Importers & Exporters of Books and Periodicals  
38 Suchou Hutung, Peking, China

# PEKING REVIEW

北京周报

(BEIJING ZHOUBAO)

A WEEKLY MAGAZINE OF CHINESE  
NEWS AND VIEWS

May 27, 1958

Vol. I No. 13

## CONTENTS

<b>ROUND THE WEEK</b>	4
Hopei Beats the Drought; "One Love and Three Fears"; Rural Universities; Out of the Blueprint Stage; Bridging the Yellow River; Summer Shopping; Music in the Air	
<b>ARTICLES</b>	
Industrializing China at High Speed	6
Korea: Two Worlds	
— Wang Yu-chang	8
New Farm Implements	
— Yang Min	10
China's Monetary System	
— Tseng Lin	12
A Boost to Rural Electrification	
— Hsu Lu	15
Kuan Han-ching and His Works	
— Wang Chi-szu	16
<b>CHINESE PRESS OPINION</b>	18
The Fascist Menace in France; Soviet-Arab Friendship; Hands Off Indonesia!; Kishi's Ambitions in Asia; The Passing Show	
<b>HEALTH &amp; MEDICINE</b>	20
<b>CHINA AND THE WORLD</b>	21
Burmese Speakers Here; Good Business in Canton; Trade News; Briefs; Visitors; Moscow Symphony in Peking	
<b>WHAT'S ON IN PEKING</b>	22

Published every Tuesday by PEKING REVIEW,  
Pai Wan Chuang, Peking (37), China  
Cable Address: PEKING 6170

Post Office Registration No. 2-521

Printed in the People's Republic of China

## COMING

Our next and forthcoming issues will carry documents and reports on the Second Session of the Eighth National Congress of the Chinese Communist Party held in Peking, May 5-23, 1958.

## Lebanese Fight Eisenhower Doctrine

**M**OUNTING resistance to U.S. interference is evident in Asia, Africa and Latin America. Latin America's "greeting" to Vice-President Nixon has given Washington headaches and sleepless nights. But that's only part of the story.

Testifying before the Senate Foreign Relations Committee on May 19, Deputy Under-Secretary of State Robert Murphy bemoaned the spreading anti-U.S. demonstrations in various parts of the world. Senator John F. Kennedy, influential Democrat, sees danger signs for the U.S. everywhere. "We are confronted with a deepening crisis in world affairs," he wails. "Lebanon, the Middle East, Algeria, North Africa, Indonesia, Latin America—every part of the world is in flames or in ferment."

Things are getting really hot these days for the imperialist ruling circles of the U.S. who assume the right to butt into other nations' internal affairs as they please. As one American commentator put it, "it is just one damn thing after another."

The march of events in Lebanon is particularly grim.

It is a long coveted goal of U.S. foreign policy to dominate the Near and Middle East and convert it into bases serving the global war strategy of Washington. The architects of U.S. foreign policy have tried every trick at their disposal to suppress the struggles of the Arab countries for national unity and independence with the hocus-pocus nonsense of "Communist menace" and the sinister tactics of "divide-and-conquer." The Eisenhower Doctrine was created as the cloak for precisely this purpose.

But the rapid development of the national liberation movements in the Middle and Near East has dealt one blow after another to the colonialist ambitions of the United States. U.S. efforts to line up more Arab countries in the Bagdad pact have flopped, and the Bagdad bloc is coming apart at the seams. The threatened U.S. military invasion of Syria was foiled. The birth of the United Arab Republic put a spoke in the wheel of the U.S. efforts to split the Arab countries.

The people of Lebanon have taken their stand against the Eisenhower Doctrine. It came as no surprise that President Eisenhower described the situation in Lebanon as "grave" and declared that he was "on the alert on an hour-by-hour basis, watching the situation closely."

U.S. intervention in Lebanon has been stepped up. U.S. arms shipments are pouring into Lebanon for use against the Lebanese. The U.S. Sixth Fleet and the British Mediterranean Fleet held manoeuvres in the eastern Mediterranean as a deliberate "display of allied military power."

The United States has stepped up its intervention in Lebanon at the very time when it is dangerously playing with fire in Indonesia. Against the background of the deepening crisis in the United States, these new foreign adventures also show that Washington is trying to combat the crisis by intensifying militarism to boost arms production.

U.S. intervention in Lebanon and Indonesia threatens peace. This is something the peoples of the world will not tolerate. China and the Soviet Union have sharply warned against U.S. interference in the domestic affairs of other countries.

With the support of the anti-imperialist and peace-loving peoples of the world, there can be no doubt that the people of Lebanon will foil the U.S. conspiracy against them if they unite and stand up for their national independence.



# ROUND THE WEEK

## Hopei Beats the Drought

Hopei is experiencing its severest drought in 30 years. For about 300 days on end there was hardly any rain, barely enough to sprinkle the surface of the parched land. In the past this would have spelt certain disaster, much as the people would have tried to save themselves. The fields from one end of the province to the other would have hardened and cracked, the crops would have died, the people would have starved to death or fled the villages.

Today, when nature is again menacing the crops, the 40 million inhabitants of Hopei, nearly the size of the population of France, have met the challenge as organized members of collectives, not as individual peasants fending for themselves in the old days. Not only are they fighting back gamely to wrest the land from the grip of drought, but they have turned the battle into a campaign to transform nature. Their motto is "to sow even in the absence of rain and to reap a rich harvest in spite of drought."

Hard work, a united and organized will and the active help and guidance of the Communist Party yielded immediate results. Difficult as it was, irrigation was brought to 20 million *mou* of wheat-land, which is several times the figure of former years. More than 54 million *mou* of land were sown to crops, fulfilling 64 per cent of the spring sowing. And to cap these hard-won successes they decided to extend the area of irrigated land from its present 60 million *mou* to 100 million, literally "taking advantage" of the drought.

While the drought has been held at bay, the people of Hopei have turned their attention to precautions against floods. For thousands of years "drought in spring and floods in autumn" had come to the peasants of Hopei with heartbreaking regularity, almost like a law of nature. This is now being altered. At a conference that ended last week the provincial authorities of Hopei mapped out a new type of programme. Flood-prevention work in previous years sought mainly to build protection against flood waters, but this year the character of the work has been changed to making flood waters, if and when they come, serve the purposes of agriculture. This is the spirit of labour, the spirit of communism, which is talked about so much in China these days.

The people of Hopei Province exemplify the high spirit of the Chinese

people in their efforts to conquer nature, the spirit that makes China what she is today.

## "One Love and Three Fears"

This spirit is also well illustrated by the way the people of the Inner Mongolian Autonomous Region have been transforming the 150,000 square kilometres of desert which account for one-tenth of the region's land. In spite of difficulties, trees and grass now grow on 210,000 hectares of desert in the Cherim and Ikh Chao Leagues (administrative divisions in Inner Mongolia). One of the drifting deserts, which has moved nearly two kilometres to the east in the last 30 years or so, has been halted by the efforts of the herdsmen. In a number of places about 80 per cent of the shifting sands have been brought under control. Food output has increased and sheep graze under the trees planted in the last eight years.

In an article published in the *Renmin Ribao* last week, Ulanfu, First Secretary of the Inner Mongolian Regional Committee of the Communist Party, outlined Inner Mongolia's development programme in the course of which he reviewed its struggle against the desert. He said the herdsmen's experience in mastering the shifting sands of the Gobi is summed up by them in the following saying: "The sands have one love and three fears — love of wind-borne drought and fear of water, grass and trees." It was by taking full advantage of these fears that the herdsmen tamed the shifting sands in Inner Mongolia. A special government department in charge of transforming the desert and a research institute have been set up to guide the work. The target is to stop the movement of the shifting sands in the entire region in the next seven years and to effect a drastic change in the desert areas within 15 years.

## Rural Universities

Yenan — once the nerve-centre of the Chinese revolution — will have its own university this summer. The finishing touches are now being applied to get the university ready for the next term. In the first year some 200 students, mostly of worker and peasant origin, will be enrolled. They will be trained as agricultural experts and technicians to develop the economy of the region. It is expected to accommodate over 3,000 students within the next three years.

The university will set itself up in the famous cave buildings which once housed the Central Committee of the Communist Party of China. Apart from the classrooms and auditorium, the living quarters for both students and faculty will be in the earth and stone caves, carrying on the Communist Party's great tradition of simplicity.

Like other universities established in the countryside, the aim of the new university at Yenan is to help the rapid expansion of industry and agriculture, with particular emphasis on the latter at present. It will also contribute to the drive to wipe out illiteracy among the peasants.

Quite a few enterprising counties have also set up institutes of higher learning. Hsushui County in Hopei Province is conspicuous among them. It is one of the most developed counties in north China, with an excellent record in irrigation work and enjoying recent fame as the county that sent a 500-member drum band to march in Peking's May Day parade. Hsushui has set up a new university to answer the needs of the peasants who want to acquire knowledge of modern science so as to tackle the many problems confronting them as the technical revolution begins to unfold in the countryside.

The cities in China, in the past, monopolized the facilities of university education. In the old days only the urban rich could afford to send their sons and daughters to universities and colleges. This began to change after liberation, when students of worker and peasant origin were provided with opportunities to study at the institutes of higher learning. The establishment of universities in the rural areas is a new trend illustrating the headway of the cultural revolution in rural China.

## Out of the Blueprint Stage

One thousand representatives from all parts of the country gathered in Shanghai to witness the opening of a model nitrogenous fertilizer factory — the prototype of the chemical fertilizer factories that will be set up in the 2,000 counties of China.

Hou Teh-pang, the well-known Chinese chemist who is Vice-Minister of Chemical Industry, supervised the designing and construction of this model factory. It has many distinctive advantages: it calls for a small investment of 3 million yuan, takes less than six months to build and is easy to operate technically. The nitrogenous fertilizer produced in the first year is sufficient to increase output of grain by 48 million catties, or ginned cotton by 8 million catties, valued at 3



to 6 million yuan. The capital invested can thus be recovered in a year's time. Thirty-six factories of this type, with equipment to be supplied by Shanghai and other cities, will be built in the course of this year. The day is not far off when modern fertilizer factories will be operating in counties throughout China. But the growing needs of the farming co-ops must be met now. A cheap and quick way to make chemical fertilizer, devised in a little known county in Szechuan Province, has attracted national attention.

In the last four months **Fengchieh County** has succeeded in making ammonium sulphate, ammonium bicarbonate, ferrous sulphate in the *tu* (native) way, which is simple, economical, and quick. More than a hundred farming co-ops set up factories, small and make-shift affairs, to produce these chemicals. Other farming co-ops in the county will soon be trying their hand at this industry too. Fengchieh County's annual output is estimated at 8,000 to 10,000 tons. Eighteen provinces have sent representatives to Fengchieh to learn from its experience, for this successful *tu* way goes far to help meet immediate needs.

## Bridging the Yellow River

If you journey by rail from Peking to Canton, you are sure to be attracted by the towering cranes as you approach the Yellow River at the ancient (3,000-year-old) city of Chengchow. At this busy junction in Honan Province, where the Peking-Canton express crosses the Lung-hai line, work has begun on a new bridge to span the Yellow River.

Stretching for 2,890 metres over 71 arches, this new Yellow River bridge will be the longest of all the major bridges now being built in China. It will have a foundation 40 metres deep, as against the 16 metres of the old bridge. It will be double-tracked and carry all types of locomotives. The old bridge, built by a Belgian firm 54 years ago, carries only small locomotives at a crawling speed of 15 kilometres per hour. Heavy traffic following the country's rapid economic expansion makes the construction of a new and bigger bridge an absolute necessity. Furthermore, a huge reservoir is now being built at Sanmen Gorge on the middle reaches of the Yellow River. When the project is completed, the water from the reservoir will wash away the sand and make the river-bed 27 metres deeper. This, of course, will end the usefulness of the old bridge, with its short piers.

The engineering job is in the capable hands of the men who built the Yangtse Bridge, opened to traffic last October. The workers, engineers and administrators are determined to advance the date of completion originally set for 1960,

in keeping with the quickened tempo of construction in China these days. The new bridge will contribute to the further development of Chengchow, which is fast becoming an important textile centre of the country with its five modern textile mills boasting 400,000 spindles.

## Summer Shopping

Customers can pick and choose to their hearts' content when they go shopping for the things they need this summer. Many new products have appeared on the market. The shops in the cities, from Peking to Canton, from Shanghai to Chungking, all have a greater variety of things and are enjoying a brisk trade.

Shops in Peking are selling at least a hundred new types of fabrics. Chinese-made nylons, socks and shirts, have come on the market in large quantities for the first time. New styles of blouses made in Shanghai are so popular with the young girls in Szechuan Province that they sold out within an hour of their appearance on the counters. More clocks, wrist watches, radios, and sewing ma-

chines have been sold, indicating growing purchasing power.

In quality too the goods are superior to those produced last year. Cotton prints, footwear, cosmetics, etc., have won the approval of the consumers. Shop assistants in Shanghai are offering a new product, unbreakable enamel saucers, which they demonstrate to the customers by dropping them from a certain altitude to prove that the enamel doesn't come off at all. Or, specially made plastic hair-clips with a pleasant fragrance, now a favourite with young women.

While increasing their volume of sales, the cities are also doubling their effort to make sure a steady supply of goods goes out to the villages for their forthcoming record harvest. In Tientsin alone, the amount of consumer goods going to the countryside this summer increased by 20 per cent each day as compared with last year, a record for this north China port city. Noteworthy is the supply of farming machinery to the co-ops — boilers, gas-driven motors, water-wheels, etc. — which has increased 51 times as compared with last year.

## Music in the Air

When a man feels fine, he hums a tune. So does a nation. China is in quite a humming mood now. In the last few months thousands of new songs have been written and sung by the people. Music is in the air. You hear it everywhere.

In response to readers' requests, the country's leading newspaper, *Renmin Ribao*, now devotes a section of its cultural page to a new feature — *Song of the Week*. The new department was inaugurated on May 22. The selected Song of the Week will appear regularly every Thursday.

The first song *We've Grown Up Together*, complete with score and lyrics, is by Ma Ke, the well-known composer and music critic.

Another sign of the singing mood is the new monthly magazine *Children's Music*, published since January of this year. It is winning a wide audience, especially among the teen-agers. The editors have made a study of the likes and tastes of the different age-groups among school-children and angle the magazine accordingly. Songs and folk-songs suited to the different age-groups are introduced in each issue. Many have become hit tunes, like *The Careless Little Painter*, *Embroidering Hankies*, and *Our Homeland's Green*.

Not to be outdone, radio is also giving more time to the new songs and tunes. Its Light Music Programme on Tuesdays, Thursdays and Sundays is now devoted exclusively to the new, popular melodies.

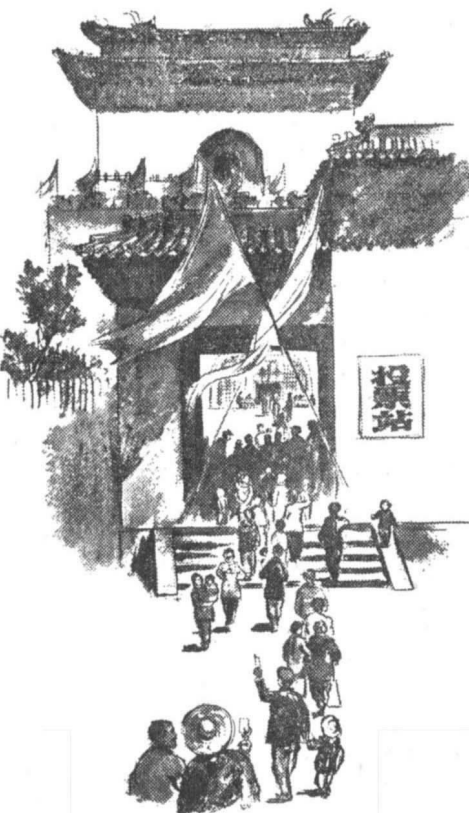

May 18 was a festive day in Peking. The people went to the polls to elect their deputies to the people's congresses of the primary levels. In most districts nearly 100 per cent of the electorate turned out to vote. By the end of this month the first phase of the general elections will be completed throughout the country, and then the election of people's deputies to the higher levels will begin. Above is a view of the polling station at Peking's Bell Tower.

# Industrializing China at High Speed

*Following is the abridged text of the "Renmin Ribao" editorial of May 12, 1958, which appeared under the title, "Expanding Local Industry on the Principle of Building More, Faster, Better and More Economically." We have added sub-heads for the convenience of our readers.*

**A** TREMENDOUS upsurge of local industry is welling up throughout the country. All provinces, many special administrative regions, counties and even townships have mapped out plans to raise the total output value of local industry above that of agriculture in about five years' time. Small factories, mines and power stations have been shooting up like bamboo sprouts in many places across the country.

Chinese industry has been in a state of backwardness for a long time. From the establishment of the "Shanghai Arsenal" (1862) and the "Kiangnan Machine-Building Works" (1865), in the reign of Emperor Tung Chih of the Ching (Manchu) dynasty, to the eve of liberation in 1949, China had very little heavy industry to speak of. There was only a slight development of textile industry as far as light industry was concerned. In general, modern industry was incomplete and its foundation was very weak. This was one of the important reasons for our poverty, backwardness and oppression by the imperialist countries.

Since liberation great progress has been recorded in our industry, many new branches in industry have been established and a preliminary foundation has been laid for the country's industrialization. But the industrial level prevailing today does not match the need of a great country with 600 million people. China still lags behind many countries in the world even in the output of principal industrial products.

China has rich resources and abundant manpower. She has established a number of modern industries, gained rich experience in industrial construction in the First Five-Year Plan period and has enjoyed the support of the Soviet Union and other fraternal countries. All this and the wise leadership of the Communist Party together with the diligence and courage of the people, provide conditions for industrialization at the highest speed. The question now is how to realize it.

## Principles of Industrial Development

As early as April 1956 Comrade Mao Tse-tung, in his report on the "Ten Relationships" to the Political Bureau of the Central Committee of the Communist Party, dealt with the relationship between heavy industry and light industry and agriculture. To develop heavy industry most quickly, he said, it was necessary to make energetic efforts to develop agriculture. In other words, he put forward the principle of simultaneous development of industry and agriculture. This provided for the industrialization a reliable guarantee of materials, market, labour power and capital.

As to the question of how to develop industry rapidly, Comrade Mao Tse-tung in his report laid down the principle of simultaneous development of the industry run by the central authority (mainly large industries) and local industry (mainly small and medium industries). He advanced this principle in the light of the experience of industrial construction at home and abroad and especially China's experience in the First Five-Year Plan.

During the First Five-Year Plan, we stressed the development of the industry operated by the central authority. As the result of rapid development in this field, China laid a preliminary foundation for her industrialization within a very short period of time. During this period, because socialist transformation had not been accomplished and because we had not paid enough attention to local industry, the pace of growth in local industry was fairly slow. Great efforts were made in the establishment of large enterprises, but not enough attention was paid to medium and small enterprises. In the past a viewpoint prevailed that building large enterprises is economically rewarding and that running medium and small enterprises does not pay. This is, in fact, contrary to the principle of building more, faster, better and more economically.

## Medium and Small Enterprises

It is, of course, necessary to build large enterprises, which form the backbone of China's industrialization. In the future it will still be necessary to build various kinds of large modern industrial enterprises. However, it is not enough to have large enterprises alone. Medium and small enterprises must also be established in large numbers—because they do not require big investments and can spread easily. They can be completed in a short time and go into production quickly. It can be envisaged that in the future our industry will expand at a great speed when, in addition to developing industry operated by the central authorities, we have succeeded in building local industry extensively by bringing the initiative of local authorities throughout the country into play, and when we have built numerous small and medium enterprises in addition to large ones.

The line of industrial construction put forward by Chairman Mao Tse-tung is one of rallying all positive factors for building industry and one of liberating the productive forces. Simultaneous development of the industry run by the central authority and local industry is designed to remove the fetters from the expansion of local industry. To develop large enterprises and medium and small enterprises simultaneously is to eliminate the limitations on the establishment of medium and small enterprises. All these are co-ordinated and the development of the one promotes the development of the other. This is the concrete way for China to industrialize at a high speed.

China now has more than 20 provinces and autonomous regions, more than 180 special administrative regions and autonomous *chou*, more than 2,000 counties and more than 80,000 townships. Should local industry be built up in every province or autonomous region, in every special administrative region, in every county and every township, it would amount to an impressive figure. A single Chinese province is larger than many of the European countries. Belgium has a population of more than 8.9 million and a territory of more than 30,000 square kilometres. But her steel output has reached 6 million tons a year. China will overtake her in steel output only this year. If every one of the more than 20 provinces and autonomous regions makes energetic efforts to develop its industry there can be no reason why, in ten or twenty years, China's total steel output cannot surpass Belgium by ten times or twenty times.

Facts have proven that to develop industry on the principle of building more, faster, better and more economically, we must develop the industry under the central authority simultaneously with local industry, and expand large enterprises alongside with medium and small enterprises. This principle defined by Comrade Mao Tse-tung was confirmed by the Eighth National Congress of the Chinese Communist Party in September 1956. The third plenary session of the Party's Central Committee in October 1957 also decided on the changes in the industrial, commercial and financial systems of management and on the transfer of a large part of the power of management from the central authority to local governments. All this, coupled with the rectification campaign and the struggle against the rightists, has greatly stimulated the enthusiasm of the local authorities to build their own industries. The simultaneous development of large industry by the central authority and of the medium and small industry by the local authorities on the basis of over-all planning and co-ordination is also the mass line in industrial construction.

As events in the past few months have shown once the initiative of the local authorities to build industries on their own is brought into play a tremendous material force is quickly released. According to preliminary statistics, it is planned that the total industrial output of Kansu, Shansi, Yunnan, Kweichow, Hunan and Honan Provinces will all increase, in terms of value, by over 50 per cent compared with last year; the rate of the growth of local industries throughout the country will possibly reach 37 per cent or more this year. To build up their own industries, people in Kansu, which has always been a relatively poor province, succeeded in collecting a sum larger than the total amount of money invested by the state in the local industries of the province during the last three years.

### Large Potentialities

According to the result of a recent study by the central ministries and departments concerned, the potentialities for the development of local industries, both medium and small-sized, are very large. It is estimated that in every county with adequate resources, mainly coal and iron, it is quite possible that at least one small coal mine, one small chemical fertilizer plant, one small coal carbonization plant, one small iron smelting plant, one small cement plant, one small power station and one workshop repairing all sorts of machinery can be built in a matter of only a

few years. Construction of these industrial plants will cost about 12 million yuan. It is not very difficult for a county to raise that sum in five years or a little longer, and once such plants are built, the industrialization of that particular county is complete. There are more than two thousand counties in the country, and, according to existing data of resources there are over 1,500 counties with coal deposits and over 200 with iron deposits. If such industries are built in these counties, the pace of the industrialization of the country can be greatly accelerated and it will be quite possible to turn our country into a powerful industrialized state sooner than planned.

The task of the local industries is to serve agriculture (this being fundamental), to serve the large industries of the state, to answer the daily needs of the people in town and countryside and to produce goods for export (mainly processing agricultural products and making native and special products). To fulfil this task, first of all, it is necessary to clear up the mysterious conception about industrialization, to firmly stick to the mass line for industries to be created and run by the whole Party, by the authorities at all levels. Officials below the county level must be encouraged to learn to run not only co-operatives but also factories. All provinces and autonomous regions, while making efforts to realize the plan for the forward leap in agriculture, must see to it that the total output value of local industries surpasses that of agriculture in five to seven years.

### Seven Points

In making plans for the development of local industries, attention must be paid to the following things:

First, over-all planning and strengthening of leadership are needed. There should be division of labour and co-ordination in industrial production based on the resources and the existing industrial foundation in various areas. A rough plan is necessary not only for the whole country, but also for the various provinces and autonomous regions. At the same time, according to experience gained in building local industries, their layout should generally rely on an existing industrial city as its technical centre; a number of county seats should be chosen as the key points linking the industrial city with the local industries in various counties; a co-ordinating system should be built up extensively between different regions and enterprises so as to form an industrial network, in which the industries in the cities are co-ordinated with those in the countryside, large industrial enterprises with medium and small ones. Arrangements should be made by the authorities of different regions according to the concrete conditions in the locality.

Secondly, the principle of running enterprises industriously and economically must be applied to the development of local industry. It is necessary to make do with simple factory buildings and equipment, to utilize fully the existing materials and manpower and to strive to build more industries at less cost.

Thirdly, in establishing new enterprises, priority must be given to the establishment of enterprises serving agriculture and the big industries. There should also be a proper development of the industries serving the daily needs of the people in town and countryside in accordance with the resources and markets available. In general, the newly built enterprises must be mainly medium or small-



sized ones; industries built by units below the county level must be, in the main, small ones serving the agricultural production in the county concerned.

Fourthly, except for those relatively large and important construction projects, which will be financed mainly by the central authorities, funds needed for the ordinary construction projects should mainly be raised by the local authorities. Local funds will mainly come from the local finance and from the funds accumulated by the local industrial enterprises, the handicraftsmen's co-operatives and the agricultural producers' co-operatives.

Fifthly, local industries below the county level may be varied in form. Roughly, there are the following forms: those run by the county authorities, by the township authorities, those jointly run by the county authorities and the co-operatives, by the township authorities and the co-operatives and those run by co-operatives. Small industries run by the agricultural producers' co-operatives will mainly produce things for their own use, such as repairing farm tools, processing and manufacturing fertilizer and processing a small amount of farm produce. Generally speaking, it is better for small industries in the countryside to take the form of those jointly run by the county authorities and the co-operatives or those run by township authorities. It will be best if among the industries run by the county authorities there is a multi-purpose factory because it will be easier for such a factory to adjust itself to the seasonal changes in the countryside, to adjust the labour force in a unified and flexible way and

to make more rational use of the technical equipment and the circulating funds. It will become the core of the industrial network in the countryside.

Sixthly, while developing local industry, we must also find out the real conditions of the existing enterprises, making full use of their potentialities, having them expanded or reconstructed according to need.

Lastly, in view of the fact that this year most of the money, materials and manpower of the various regions will be devoted to the great forward leap in agriculture, we shall mainly build small enterprises, especially those making improved farm tools, repairing agricultural machinery and exploiting non-ferrous metals and coal pits, which require little investment, take less time to build and bring quick results. As to those industries which need larger investment and involve more complicated technique, this year the emphasis must be put on making preparations for their future construction — several experimental medium and small enterprises may be established in every province and autonomous region so as to acquire experience and create conditions for their future development.

The fine prospects of the industrialization of our country can now be visualized. We must summon revolutionary drive and battle for more advantageous positions, to build more, faster, better and more economically, in the development of local industries. We hope the flowers of local industry will blossom in all parts of the country so that China will realize her socialist industrialization as soon as possible.

## Report from Pyongyang

# KOREA: TWO WORLDS

by WANG YU-CHANG

NOT long ago, at a press conference in Pyongyang I came across a cloth dealer named Kim Taik Sun who fled to the North with some other South Koreans on a South Korean airliner on February 16 of this year. He was apparently impressed by what he saw in the North and I could see that he was still excited when he talked to me.

"We couldn't believe our own eyes when we saw those heavy machines on display at the Industrial and Agricultural Exhibition here. We were told that they were produced by the industrial plants of the Republic that were built after the war. By contrast, industry in the South is daily on the decline. There, all we have are small workshops making neckties, shirts and alcoholic drinks. But even these things have to be labelled with American trade marks before they have a chance to be sold. In Seoul there are firms specializing in designing spurious American trade marks. American goods are pouring into South Korea and our own business men and industrialists simply find it impossible to cope with this situation."

Both Kim and his companions were also impressed with the newly paved boulevards and the new multi-

storeyed workers' living quarters along the main streets in Pyongyang. They compared the city with Seoul where there was little construction after the armistice. They told me that even the street lamps in Seoul were dim and all the big buildings were occupied by the American troops and Syngman Rhee's officials. As to the working people, they have to crowd into wooden shacks at the outskirts of the city.

### Different Policies, Different Results

Korea is now divided into two by the military demarcation line of the 1953 armistice. From 1954 to the present, the Government of the Democratic People's Republic yearly spent an average of 77.4 per cent of the total annual expenditure on economic, social and cultural development. This year, expenses in these fields will amount to 84.7 per cent of the total budget. Last year expenditures for national defence dropped to 5.8 per cent of the total budget and this year are further reduced to 5.4 per cent.

In the financial outlays of the Rhee regime in South Korea, between July 1953 and this year, military expenses amounted to an average of 55 per cent per annum, or

68.4 per cent if costs of the police force and other related military expenses are included. In its budget for this year, the total appropriation for military purposes will amount to 67 per cent of the total budget.

After the war the Korean Democratic People's Republic, a member of the big socialist family, has been given disinterested aid by other fraternal countries. In the period of its Three-Year Plan (1954-1956) alone, the Soviet Union and other fraternal countries sent the Republic equipment for factories, machines, industrial goods and daily necessities valued at several thousand million roubles and helped the Korean people restore and build many industrial plants with the latest technical facilities. These aids have proven to be a great boon to the Republic in setting up the basis for an independent economy and improving the people's living standard.

In the same period, the United States shipped to South Korea munitions, jet planes and atomic cannons to arm Rhee's troops. This so-called aid, which is instrumental to U.S. domination, was to the tune of several thousand million U.S. dollars. Other U.S. "aid" included all sorts of U.S. surplus goods, aimed to relieve American economy.

In the past five years, over 360 large and medium-sized mines and factories have been restored and built in North Korea. Last year, the value of the total industrial output was 2.8 times as much as in 1949, the year before the United States started the war of aggression. All industrial departments including the iron and steel, electric power, chemical, coal mining and light industries, have reached or greatly surpassed the pre-war level.

In South Korea, the present level of industrial production is about half as much as that in the period of the Japanese occupation. Industrial goods produced in South Korea can meet only 20 to 30 per cent of the total consumption in that part of the country. More than 1,300 firms closed in the past twelve months or so due to lack of funds, marketing difficulties or heavy taxation.

In North Korea industry is already on the path of independent development, due to the rapid restoration and growth of the heavy industries, machine-building and textile industries after the armistice. By contrast, even the small amount of industry that does exist in South Korea only serves the colonial interests of the United States. In 1957, North Korea produced 270,000 tons of pig iron and 270,000 tons of steel; South Korea produced not a single ton of pig iron and only 16,000 tons of steel. Last year North Korea turned out over 1,000 metal-cutting machine-tools, including some of the latest types; in South Korea only such simple machines as sewing machines and water pumps were produced. In 1957 North Korea produced 320,000 tons of chemical fertilizer whereas South Korea imported all the chemical fertilizer it needed from the United States at a price \$3.80 higher than the international price per ton.

### Deficiency and Sufficiency

The northern part of Korea is a land of mountains with few plains in contrast to the southern part. The former had always been a region with a grain shortage whereas in the past the latter exported grains. Today the situation is different.

The Government of the Democratic People's Republic has made great efforts to promote agricultural develop-

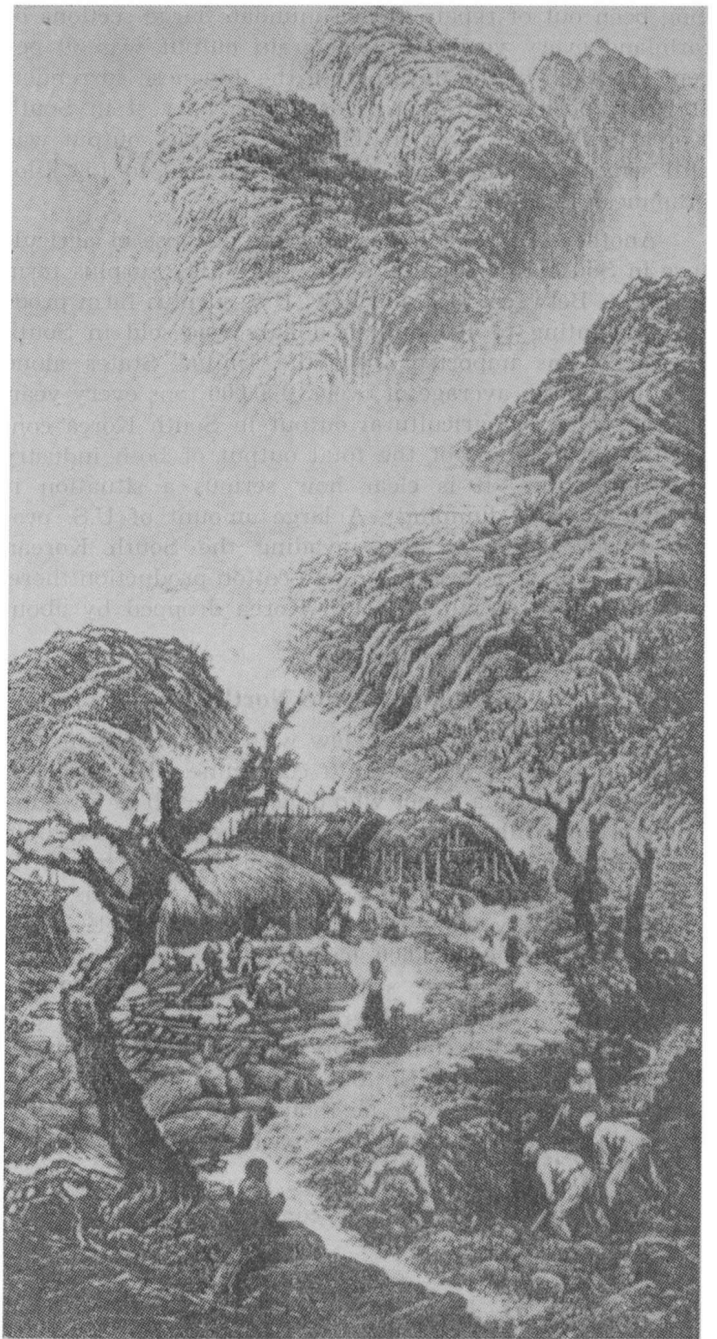

Rebuilding a North Korean village

Woodcut by Hsiu Chun

ment. In the past five years many irrigation works were built, and the land irrigated was thus expanded by 160,000 *jong bo* (one *jong bo* is approximately equal to one hectare) while 77 per cent of the paddyfields were freed from the menace of floods or droughts. An overwhelming majority of the peasants have joined the co-operatives. They introduced various advanced techniques to their farms and changed the natural conditions of the soil, turning the alkaline land along the western coast and the plateau on the Paek Tu Mountain into granaries. In the years after the armistice one good harvest was followed by another. In 1956 grain output surpassed the pre-war 1949 level; in 1957 it increased to 3,200,000 tons; this year it is expected to reach 3,950,000 tons. North Korea today is self-sufficient in grains.

In South Korea the land now under cultivation is 400,000 *jong bo* less than in the last years of Japanese rule. Because the irrigation works and river dykes have

long been out of repair, floods inundate large sections of farmland every year. In 1956 grain output was 30 per cent less than in the days before the Japanese surrender. It was reported that there was a rich harvest in South Korea in 1957 but even in that year the rice output was still some one million *sok* (one *sok* is equal to 150 kilogrammes) less than the 1937 output.

Another important reason for the collapse of agriculture in South Korea is the dumping of U.S. surplus farm produce. Between 1955 and now, U.S. surplus farm produce amounting to 130 million dollars was sold in South Korea; grains imported from the United States alone amounted to an average of over 3,400,000 tons every year. As the value of agricultural output in South Korea constitutes 80 per cent of the total output of both industry and agriculture, it is clear how serious a situation is created by U.S. dumping. A large amount of U.S. produced raw cotton is also invading the South Korean market. This is a serious blow to cotton production there. In 1957 cotton output in South Korea dropped by about 71 per cent compared with 1949.

### Looking to the North

Recently I had an interview with Choi Ki Byong, an outstanding miner in the Anju coal mine. His father, I was told, was also a miner who died as a result of a wound he received while working in a Japanese pit and could not afford medical treatment. Choi himself began to work in the mine at 12. Under Japanese rule, his daily wage was hardly enough to buy rice for himself. Now his monthly wage is 4,600 *won* (Korean currency). His real income is, however, still higher, reaching 10,000 *won* if the various rations and grants are included. He and his family live quite comfortably in one of the new houses built for the workers. He told me that he felt he wanted to work harder whenever he thought of the tragic death of his father and compared his past with his life today.

The life of the broad masses of workers and office employees in North Korea is constantly improving. By

the end of 1957 there were 844,000 workers and office employees in North Korea, an increase of 279,000 over the 1949 figure. By December 1956, the salaries of the workers and office employees was 2.3 times as much as that in 1949, while the commodity prices decreased by 50 per cent after the armistice. Towards the end of 1957, the Government of the Republic had built dwellings for workers with a total floor space of over 6,600,000 square metres. In the same period the income of the peasants too has shown a yearly increase. Last year, every peasant household which had joined the co-operative — they constituted 95.6 per cent of the total number of peasant households in North Korea — received an average of over 1,700 kilogrammes of grains, more than 430 kilogrammes of potatoes and 13,000 *won* in cash.

In South Korea, as its news agency reveals, the unemployed or semi-unemployed numbered 3,800,000. Those who are employed earn only two-thirds of the wages they were paid in the period of Japanese rule, while the commodity prices have gone up sixfold in the past five years. Although the South Korean authorities last year talked boastfully about building houses for 25,000 families, they actually built only ten in Seoul and that was all. At present there are three million people in South Korea who do not have a house to live in.

Peasants in South Korea, who are burdened with over 80 per cent of the financial expenditures of the Rhee clique, are having a most difficult time. Every year, on an average, over 55 per cent of the fruits of their labour were taken away by the Rhee authorities. Practically every spring the countryside is stricken with famine and large numbers of peasants have to leave their homes to seek a living, many of them subsisting on barks and grass.

Under these circumstances, the masses in South Korea are increasingly turning to the North for inspiration in their strivings for a decent life. And this is giving ever greater impetus to their struggle for the peaceful unification of their motherland.

## Technical Revolution

# New Farm Implements

by YANG MIN

*The National Farm Implements Exhibition, opened recently in Peking, gives a bird's-eye view of technological innovations in the countryside. This is the first of a series of articles on the subject. Articles on irrigation devices and means of transport, etc., will appear in subsequent issues.*

**A** WIDESPREAD movement for the introduction of new and improved farm tools is underway in China's villages. This marks the beginning of a technical revolution in agriculture. This is mirrored in the National Farm Implements Exhibition — the first of its kind on a national scale — opened on May 5 in Peking. The exhibition gives a graphic picture of the evolution of farm tools. Although by far the greater part of the three thousand odd

exhibits are implements improved or invented by co-op farmers in recent months, there is also a display of traditional implements and modern power-driven farm machines. They show how rapidly farm techniques are changing in China and the significance of the revolution that is taking place.

At one end of the show are tractors and combines; at the other is an iron-tipped wooden plough pulled by oxen such as has been in use for 1,500 years and is still used in some parts of Kansu Province. Such ploughs, double-row seeders and other primitive implements invented some two thousand years ago were the mainstay of China's farms at the time of liberation in 1949.



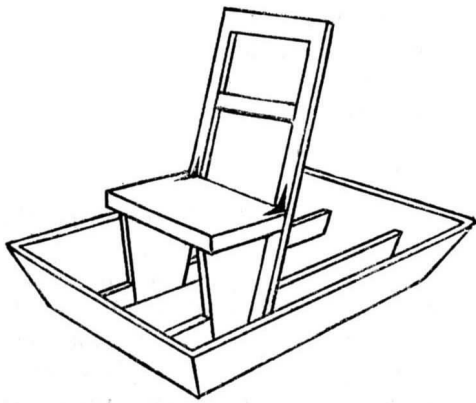

Fig. 1 Rice-transplanting float

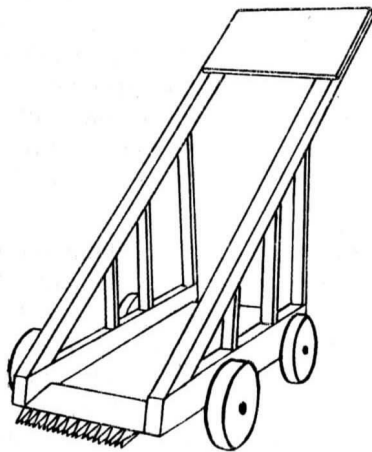

Fig. 2 Wheat harvester

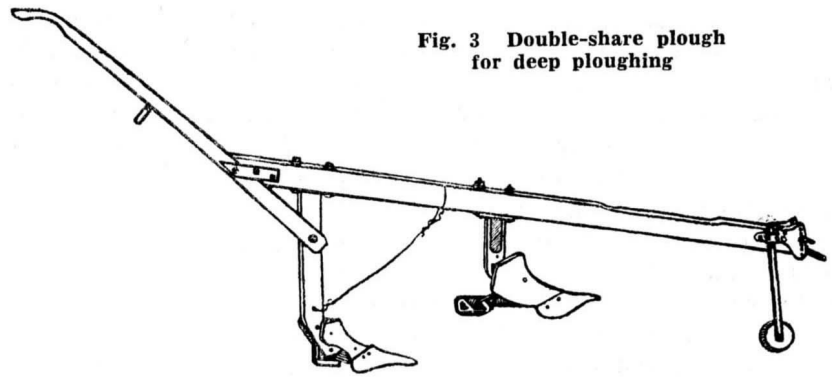

Fig. 3 Double-share plough for deep ploughing

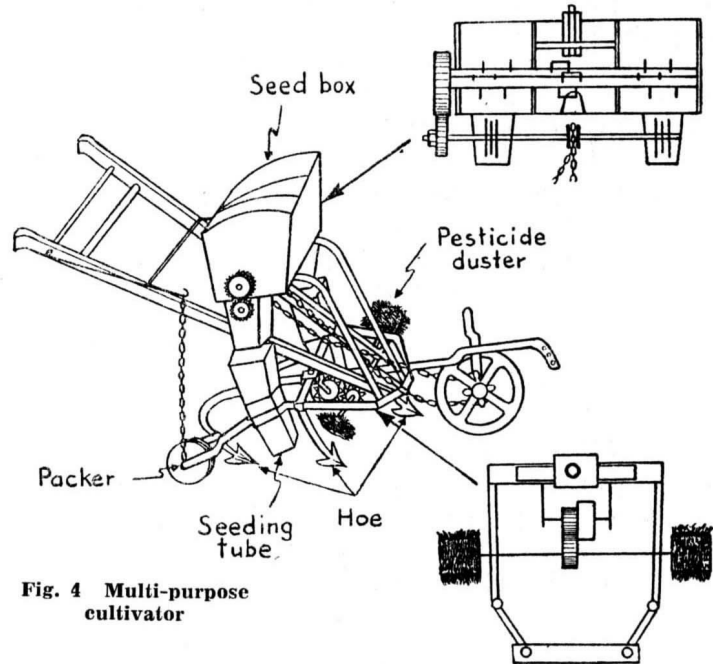

Fig. 4 Multi-purpose cultivator

The change to better tools began immediately. Liberation, land reform, the advance of the co-op movement all spurred the farmers' inventiveness. The beginnings of industrialization provided the metal and machines to make modern tools. By 1957 large numbers of new and improved tools had been introduced; more than 2.5 million new-type steel ploughs and disc harrows were in use on 234 million *mou* of land or 13.3 per cent of the cultivated area; over a thousand state farms and machine and tractor stations were set up with 26,700 tractors.

But the really rapid advance has come with the present great leap forward in agriculture. Co-op farmers in recent months have invented thousands of new farm tools and appliances. Figures from only thirteen provinces and municipalities show that co-op farmers there made 6.9 million newly invented or improved farm tools. Industry has begun to turn out tractors, pumps, and other farm machines in increasing numbers. One hundred and twenty types of tractors have been manufactured successfully on a trial basis in the first five months of this year.

### Transplanting Rice the Modern Way

The co-op farmer of today is not taking anything for granted—even the way generations of farmers have

transplanted rice. A carpenters' co-op in Kwangtung has made a rice-transplanting wooden float (Fig. 1) that ends the back-breaking toil of the old way of doing it. It is like a small, flat-bottomed boat a metre and a half long and half a metre wide. The farmer sits on a low chair on its "prow" to bend down and transplant the seedlings, pushing the float backward with his feet as the work is done. A good stock of seedlings and even the farmer's refreshing teapot can be carried at the "stern." An umbrella can be rigged above the float to protect the operator from sun or rain. This simple gadget that can be made by any handyman both lightens and saves labour.

The five rice-planting machines recently invented and displayed at the exhibition show a more advanced phase of the revolution that is taking place in China's ancient farm culture. One of the most advanced has an all-steel body with 48 mechanical hands which grasp rice seedlings and thrust them into the mud of the paddyfield as the machine moves along. With this buffalo-drawn six-row planter designed by the Nanking Farm Machinery Research Institute, a man can plant 30 *mou* a day, where the average farmer working with his hands can do only a single *mou*.

The importance of introducing such gadgets and machines is clear when one recalls that rice—a high-yield

crop—makes up over 40 per cent of China's total grain output and that the new area of 111.52 million *mou* added to China's rice acreage this year alone is larger than the total rice acreage of Thailand, one of the world's largest rice exporters.

The farm tools improved or invented by co-op farmers, village carpenters and blacksmiths are simple but ingenious. They are playing an important part in getting the big leap in farm output. One example is the hand-pushed wheat harvester (Fig. 2) invented by Szechuan artisans to replace the sickle. It is particularly suitable for small plots of land. The cutting edges moving according to the principle of the barber's clippers are worked by the wheels as the harvester is pushed forward. In a simple form its transmission and working parts operate in essentially the same manner as those of the modern combine harvester. Mechanical motive power will greatly increase its efficiency and the problem of large-scale utilization of motive power will undoubtedly be solved in the course of industrialization.

One particularly interesting innovation is a small light-weight plough designed by a co-op farmer of Honan (Fig. 3). It has two plough-shares in line on different levels. The front one cuts a furrow 20 centimetres deep and that in the rear deepens this by another 13 centimetres. It is an extremely effective animal-drawn implement for deep-ploughing. It is now being popularized throughout Honan.

#### Multi-Purpose Machines

A novel "slide-board mechanism" is used in some of the seeders devised by farmer-artisans. One perforated board slides over another and when the holes coincide, the seed drops through and is sown. Rubber cushioning around the holes prevents damage to the seed. This mechanism is dependable and is particularly suited to small seeders. It can also put in exact amounts of fertilizer while seeding.

Many multi-purpose implements have been made by the use of ingenious transmission mechanisms. It's a case

of "one orchestra accompanying many operas" as the farmers say. A cultivator (Fig. 4) built by a Hopei farmer not only weeds but can also sow, apply fertilizer and insecticide. Some home-made seeders water the fields, apply fertilizer and sow seed all in one operation. Farmers in the south have made implements that plough and harrow paddyfields at the same time. This is of great importance in saving the time necessary to switch over from two to three crops a year.

This need for economy also inspires the design of many modern tractors. The "August 1" tractor made by the Kiangsi Machinery Works is a 26 h.p. tractor, light, steady in operation and economical on oil. While it can do all the ordinary field work of a tractor, on dry or watered fields as well as trucking, it can be easily adapted to provide power for pumping water, generating electricity, grinding flour, pressing oil, etc.

One of the features of the farm tools displayed is that so many of them are designed to suit local conditions. Many of the standard implements too can be adapted to local needs. There are scores of the famous double-wheel, double-share ploughs from various provinces and nearly all have local modifications. Those used on southern paddyfields have wooden instead of iron wheels to prevent them from sinking into the mud. In some cases ski-shaped floats are attached to the wheels.

China is working hard to bring about mechanization in her agriculture. The Farm Implements Exhibition shows the resourcefulness with which her farmers are pressing ahead. They are not waiting for the future to come to them in the form of ready-made mechanization from the factories. The tractors and machines already produced by scores of engineering plants in the country show that the stage of large-scale, over-all mechanization is not so far away, but for the moment new and improved farm tools and semi-mechanized tools must be the mainstay of the farms. It is in this field that the village craftsmen and Chinese working class are making a contribution now whose importance it would be difficult to over-estimate.

## China's Monetary System

by TSENG LIN

*Director of Research Institute of Finance, People's Bank of China*

CHINA today has an independent, unified and stable socialist monetary system geared to serve the interests of the people and the needs of socialist construction. It is devised to oil the wheels of exchange in a planned socialist economy.

This is a long way from the state of affairs in old China. In those days the monetary system was tied to the currency blocs controlled by the big imperialist countries; first the sterling bloc and then the dollar bloc. Foreign banks in China were permitted to issue their own currencies. The U.S. dollar, the Hongkong dollar and the pound sterling were all in circulation. Foreign banks handled the bulk of China's foreign trade and they

controlled foreign exchange transactions. In Kuomintang times the big bureaucrat-capitalists and in particular the comprador-financial clique of the Four Big Families (Chiang Kai-shek, T.V. Soong, H.H. Kung and the Chen brothers) monopolized the business of issuing paper currency. They turned this into a racket that brought them in millions, led to the alarming multiplication of paper money, and a soaring inflation that sapped the economic foundations of the country and caused untold suffering to the people.

The amount of paper currency issued by the Kuomintang regime between 1937 and May 1949 increased 176,800 million times, reaching astronomical

figures, 21 digits to be exact, in dollars. Commodity prices in Shanghai shot up 13,884,200 million times in the same period. This financial juggling alone caused the ordinary people of this country a loss of 15,000 million silver dollars (in terms of values before the War of Resistance to Japanese Aggression).

But this was not all. Various warlords, landlords and local despots also issued their own local "currencies" to fleece the people. Huge amounts of paper money were issued by the warlords of Szechuan, Shansi, Kwangsi and Yunnan. Paper money printed by big landlords and merchants was in circulation in some counties, cities and even townships. In many cities, credit notes issued by banks, "money shops" and commercial establishments were also in circulation to the benefit of the speculators.

All this reflected the backward, semi-feudal, semi-colonial state of old China's economy. Needless to say the production and distribution of commodities and the circulation of money was planless and chaotic in the extreme. The suffering and misery caused the common man by this state of affairs is still fresh in most memories.

### The New Monetary System

This parody of a monetary system has been scrapped and replaced. The new monetary system of the People's Republic of China is a tangible manifestation of the victory of China's socialist economy over the anarchy and attendant speculation of capitalist economy. The growth of socialist construction and the rapid economic advance of recent years has put it on a firm basis.

The new currency, the *jen min pi* (People's Currency), is a socialist currency, a tool which the people's power uses to carry forward socialist construction and the socialist transformation of the country; it is an instrument for planning and calculation. It plays an important role in promoting exchange of commodities between town and countryside and in consolidating the worker-peasant alliance.

The establishment and consolidation of the new monetary system — independent, unified, stable, organized and planned in the service of the people has been of enormous significance to the success of China's socialist economy.

To develop an independent economy in China it was essential to establish an independent monetary system. This was needed to safeguard the economy as well as to expand it. One of the first steps was to withdraw from circulation all paper money issued by the reactionary regimes of the past. The Kuomintang *fapi*, *chin yuan*, and *jin yuan* notes were called in; the privilege previously accorded the imperialists of issuing banknotes in China was abolished; the monopoly the foreign banks enjoyed in handling foreign currency exchange was ended. Foreign currencies were prohibited from circulation inside China.

On the other hand, the Chinese state banks were given the exclusive right to buy foreign currencies and deal in foreign exchange. Exchange rates were set at a reasonable level. This concentration of the management of foreign exchange business in the hands of the state banks was effected so that the best use could be made of

China's foreign exchange holdings to foster her economy, and in particular industrialization, and implement her independent economic and monetary policies.

### Stable Currency

As a result of the measures taken to hold market prices stable and to give the people confidence in their new currency, the Chinese *jen min pi* enjoys an enviable stability in relation to currencies in the capitalist countries. Adjustments in the rate of the *jen min pi* in the past few years reflect this. Since the summer of 1950, the rate vis-a-vis the pound sterling has shifted from 9.8 yuan to 6.8 yuan to the pound while the rate vis-a-vis the U.S. dollar has been changed from 4.2 yuan to 2.4 yuan to the dollar. This means a more than 30 per cent increase in the yuan's value in terms of foreign exchange. Because of her independent monetary system New China has been able to guard herself against the adverse effects of inflation and currency depreciation in the imperialist countries.

Issuance of *jen min pi*, the sole legal tender in China, is concentrated in the hands of the People's Bank of China. It is both a symbol of gold and a symbol of value and performs the various functions of money. All banknotes issued in the period of the War of the Agrarian Revolution (1927-1936), the War of Resistance to Japanese Aggression (1937-1945), the War of Liberation (1945-1949) and in the various revolutionary bases have been redeemed by state banks at reasonably fixed rates and according to the real value they represented at the time they were exchanged for *jen min pi*. No one redeeming these old money issues suffered loss as a result of introduction of the new currency.

Government regulations prohibit gold and silver from circulation on the market. Private dealings in them are also prohibited. Private individuals may hold gold or silver but all commercial dealings in these metals are centralized in the hands of the state banks. All forms of token money or credit notes are prohibited from circulation. Currency may not be brought into or taken out of the country.

These measures — exclusive circulation of the *jen min pi* in the market, the adoption of a unified monetary system, etc. have insulated China's independent monetary system from the effects of the activities of U.S. monopoly capital which holds about 80 per cent of the gold of the capitalist world. There is no need to stress the advantages of this.

Gold and silver held by private individuals can be bought by the state banks at reasonable rates to increase the country's reserves and foreign exchange resources. This puts otherwise dormant stores of the precious metals to good use and stops speculation in gold and silver. Other advantages given by these measures are the ability to expand socialist credits, to adjust the circulation of currency in a planned way. All this help the growth of the national economy.

The monetary situation in the national minority areas involved special problems. In solving them the economic interests and needs of the peoples there were taken fully into account and suitable measures have been



taken to bring about a gradual unification of the currency in those areas.

The stability of China's new monetary system has been one of its outstanding features. There was a short period of instability only between October 1949 and March 1950. At that time, long years of war had left the country in a sorry plight, there was an imbalance between revenue and expenditure; speculation on the market had not yet been brought under complete control. During those six months, commodity prices in Shanghai went up by about four times. The Central People's Government immediately announced measures to deal with the situation: to unify control over finances and the economy as a whole and to achieve balances in state revenue and expenditure, in the supply of commodities throughout the country and in the cash receipts and payments of the state banks.

These measures to stop inflation were fully supported by the people. By March 1950 the runaway inflation, which had been in existence for over ten years, was brought to an end. China's currency has been stable ever since then. Market prices as a whole have also been stable, though necessary adjustments have been made. If the price index of March 1950 is taken as 100, it dropped to 92 in 1957. Government purchasing prices of agricultural and subsidiary rural products have gone up, while prices of industrial goods, especially heavy industrial products, have been reduced. The tendency is for the differential between industrial and agricultural prices to narrow down.

### Helps the National Economy

This monetary stability has been an important factor in putting a stop to speculation, expanding industrial and agricultural production, promoting the exchange of commodities, strengthening state finances, expanding socialist credit and improving the people's living standards.

Maintenance of this monetary stability means in turn that the whole national economy should be running efficiently: funds must be supplied to socialist commerce on time for the purchase of essential industrial and agricultural products, attention must be given to both the needs of national construction and the people's livelihood, and a proper ratio must be maintained between accumulation and consumption. National finances and bank credits must also be brought under a unified plan and co-ordination without resorting to note issues to redress financial deficits. The amount of paper money in circulation must be determined in the light of the needs of commercial activity. Any rise in the people's purchasing power must be made to correspond with the increase in the production of consumer goods.

The success of China's monetary policy is shown by the fact that the money market and commodity prices in China are much more stable than they are in the leading capitalist countries. Compared with 1950, for instance, wholesale prices in China were 8 per cent lower in 1956. During the same period wholesale prices in the United States went up by 10 per cent, in Britain by 34 per cent, in France by 30 per cent, in West Germany by 17 per cent and in Japan by 44 per cent.

Planned and organized circulation of currency is a basic principle in China's monetary system. This is made possible by the existence and steady expansion of state-owned industry and commerce which are socialist in nature and owned by the whole people, the establishment and growth of the state banks and adoption and consolidation of a unified, independent and stable monetary system. The very foundation of planned and organized circulation of currency, however, is the planned production and circulation of commodities in the national economy. The People's Government early began to adopt the necessary measures to bring this about. In April 1950 the government issued a cash control order which lays it down that state enterprises and government departments are permitted to keep only a limited amount of cash in hand. Anything over and above this amount must be deposited in the People's Banks in their localities. They must use cross cheques in all their transactions, using cash only for paying wages, purchasing farm products and defraying small expenses. During the past few years this order has effectively guided the circulation of currency.

The movement of money has been greatly simplified since a decisive change was brought about in the socialist transformation of the individual and private capitalist economic sectors of the national economy. Since then the people receive cash mainly in the form of wages or as part of the income earned by members of farming co-operatives. They pay out cash mainly for the purchase of consumer goods from socialist commercial establishments. Cash payments made by the state banks are mainly for the payment of wages, and the purchase of agricultural and subsidiary farm products. Their cash receipts come mainly from socialist business establishments from the sale of goods.

For these reasons the question of adjusting the circulation of currency does not lie simply in increasing or reducing the amount of currency in circulation on the market. The most important thing is to bring about planned adjustments in the economic relations between the state and the people. This is of course connected with the resolution of the contradiction between the needs of national construction and the people's livelihood, between accumulation and consumption.

A planned and organized monetary system centred on the state banks facilitates the proper adjustment of economic relations between the state and the people and the gradual improvement of the people's living standards on the basis of expanded production.

China's new monetary system has already played and will continue to play a most important and positive role in bringing about the socialist transformation of Chinese economy and in the growth of China's socialist construction. It is one of the key tools of the people in building their socialist future.

#### CHINESE WEIGHTS and MEASURES at a GLANCE

1 *mou* = 0.06 hectare or 0.1647 acre

1 *tan* (picul) = 0.05 ton or 0.984 hundredweight

1 *chin* (catty) = 0.5 kilogramme or 1.1023 pounds

# *A Boost to Rural Electrification*

by HSU LU

**T**HE capacity of small, rural hydro-power stations will be increased by more than 900,000 kilowatts in 1958, reports from various parts of the country indicate. Last year they had a capacity of only 20,000 kilowatts.

Small stations with a mere capacity of tens of kilowatts may not seem to be of any significance to big cities, but they do mean much in a township or farming co-operative. Small power stations can free the peasants from the burdens of heavy manual labour and pave the way to putting agriculture on a mechanized and electrified basis.

## **Saves Labour Power**

In the present agricultural leap forward, labour shortage is becoming a problem and electric power provides a solution. The 16 hydro-electric power stations and 21 water-powered mechanical stations (mills to process farm produce worked by water power) in Yungchun County, Fukien Province, can relieve about 600,000 labour days a year. Industrial enterprises run by local farming co-ops or township authorities urgently need electric power too.

The establishment of large numbers of small hydro-electric power stations is an effective way to accelerate rural electrification. Suited to the rural economic and technical conditions, they have a very promising future. Their low cost of building and equipment places their construction within the financial means of the co-op farms. A 50-kilowatt station, it is estimated, needs a total investment of 20,000 yuan. It can generate enough power to irrigate 2,500 *mou* of land and do some processing work or supply lighting to 5,000 people. For a farming co-op with 5,000 members this averages only four yuan per person.

Small stations can do with rather low waterhead and can be widely built on creeks or even ditches. A station in Chinghai County, Hopei, was built on a 1.2-metre waterfall. Tests have shown that it could generate power even when the waterhead was as low as 70 centimetres. This characteristic makes the large-scale construction of small power stations a practical possibility throughout rural China.

Neither high-precision equipment nor expensive materials are required. Local engineering works and locally made building materials suffice. Wooden parts can be used to replace steel ones and wooden turbines are commonly used in Anhwei Province. Local masons, carpenters and farmers can be readily organized to learn the comparatively simple techniques for building small power stations and a station generally needs only two or three people to take care of its operation. All this is within the ability of farming co-ops.

Small stations, however, do have distinct shortcomings—they are short-lived, their capacity is small and output is low. Because of this they cannot compare with big power stations. But they have their merits too. They are simple, economical and easy to build. The widespread construction of small stations does not in the least minimize the significance of big power units. China has built many large power stations in the past and will build more in the future. Large power stations will undoubtedly form the core of China's electrification.

Though small power stations can only meet the needs of the infant stage of rural electrification, they are of great use today. They fall in line with the present general line of building socialism in China—building more, faster, better and more economically. In the course of setting up thousands of small power stations, a large corps of technicians will be trained in a practical way. A firm foundation for future development will be laid.

## **Technical Equipment**

Experience has been amassed in solving the technical, equipment and financial problems involved in building small stations. The Tientsin area tackled the problem of training technical personnel in two ways. On the one hand, local ironsmiths, carpenters, masons and other people went to existing stations to acquire the necessary skill and experience. On the other hand, local technicians and school teachers were invited to give technical advice and on-the-spot instruction. Assistance can also be obtained from model stations run by local water conservancy and industrial organizations. The standard designs for different types of small hydro-power stations and related reference materials have also proved helpful.

In addition to old equipment made use of, the supply of generating equipment depends mainly on local plants which in turn can count on help from large engineering works. Most of the existing stations are financed entirely by the people and government loans constitute only a small fraction of the total investment in the others. Szechuan Province devised a new method to accumulate capital that is being used in other places too. The Szechuan peasants first build mechanical stations, using water power, to process farm products and then use the money earned in this way to build small hydro-electric power stations.

Today there are only several hundred small hydro-power stations in the countryside, but they are spreading fast. The electric sparks are still small and far between in the vast territory of rural China. A spark, however, can start a prairie fire and in a matter of a few years small hydro-electric power stations will cover the entire country.

# Kuan Han-ching and His Works

by WANG CHI-SZU

SEVEN hundred years ago the works of Kuan Han-ching, great 13th century realist playwright, made their appearance in China. The anniversary is being commemorated in various parts of the world this year at the recommendation of the World Peace Council. A meeting in commemoration of Kuan Han-ching will be held in Peking at the end of June.

The Yuan dynasty (1279-1368), in which Kuan Han-ching lived, was the golden age of the Chinese drama. Many fine playwrights were active at this time, and more than 200 of their writings are still extant. Kuan Han-ching was the best of them all.

Historians in the feudal days had little sympathy for the popular arts. That is why we know so little of Kuan Han-ching's life. None of the dynastic historians or classicists thought his biography worth recording. Our present information, gathered from his own extant poems and plays and some writings of the period, indicates that he lived between 1225 and 1300 and wrote his plays in the latter half of the 13th century.

At that time he, like most better-known playwrights, lived in Tatu, the present-day Peking. The ballad and opera performers there, as elsewhere in China, were sing-song girls who usually came from the lowest social strata and were treated with contempt by men of the ruling class. Kuan Han-ching apparently spent much time with these girls and the common townspeople, gaining an understanding of their feelings and thoughts, and sympathizing with them politically. He mastered the techniques of the folk arts and the language of the ordinary city-dwellers. This was a source of his great achievements as a dramatist.

## Some of His Plays

Kuan Han-ching wrote more than sixty plays. But only 21 are now extant (three of them in fragmentary form). These may be divided into three categories: histories, dramas of social conflict, and romances.

Among the historical plays are *Lord Kuan Goes to the Feast*, *The Dream of Western Shu*, *Mourning Tsun Hsiao*, *Pei Tu Returns the Belt*, etc. Though they took their themes from the past, they reflected the conditions



Kuan Han-ching

Portrait by Li Hu

in Kuan's own time. *Pei Tu Returns the Belt*, for instance, tells how an official of the court, refusing to truckle to a superior, was imprisoned on a framed-up charge of bribery. The scene is set in the Tang dynasty (618-907) but the play really exposes the corrupt Yuan government.

Kuan's genius as a realist is most marked in the second category of his works, those dealing directly with contemporary social conflicts. The oppressor and the oppressed alike are vividly portrayed, and in the acute struggles between them, the playwright shows clearly where he stands — on the side of the oppressed.

Kuan's *Snow in Midsummer* has been called the best tragedy of the Yuan period. It is about the young widow Tou Ngo and her mother-in-law Mrs. Tsai, who lived together in poverty. A scoundrel, Chang Lu-erh, using the pretext that he had once saved Mrs. Tsai's life, pushes his way in as a lodger. He wants to make Tou Ngo his wife but is rebuffed. So he poisons the food prepared for Mrs. Tsai to get her out of the way. But the meal is eaten by his own father who dies. Chang trumpets up a charge of murder against Tou Ngo. A corrupt judge sentences her to death. Three years later her father Tou Tien-chang, who has become a government dignitary, passes through the county. His daughter's ghost, appearing in a dream, tells him all that has happened. The real criminal then gets his deserts.

Tou Ngo, depicted as a virtuous woman with an unyielding spirit, can be said to symbolize the common people of the time. The judge typifies the political darkness and the villain Chang Lu-erh the darkness in society. These two forces work together; the people's strength is still a feeble sprout, so Tou Ngo's tragedy is inevitable. But her struggle and the final redress show how the people think and what they want.

If *Snow in Midsummer* is the best Yuan tragedy, *Rescued by a Coquette* is one of the best comedies telling how Chao Pan-erh, the heroine, defeats the machinations of the official's son Chou Sheh. In this play, the writer exposes the hypocrisy and cruelty of the privileged class and pays tribute to the sympathy and chivalry which people of the oppressed class have for one another.

In the plot, Sung Yin-chang, a sing-song girl, is married to Chou Sheh who maltreats her in every way. Chao

The author is a professor at the Sun Yat-sen University in Canton.



Pan-erh, her sworn sister, decides to help. She pretends to fall in love with the wicked Chou Sheh who divorces his wife, after which his feigned *inamorata* ridicules and abuses him, and the two women go off together.

The principal characters — Chao Pan-erh and Chou Sheh — are delineated by the playwright with brilliant realism. Through a conflict in Chao Pan-erh's mind, he brings out her nobility of spirit. In the second act, when Sung Yin-chang's mother showed her daughter's letter asking for help, Chao recalls how Sung flouted her advice and insisted on marrying Chou. At first she refuses to do anything, but when she ponders over the common fate of the oppressed, she decides to help.

Chou Sheh has the qualities common to the feudal ruling class — he is a cruel hypocrite. He is also a big merchant and spendthrift, which adds wiliness to his mental arsenal. When infatuated by Sung Yin-chang's beauty, he decides to possess her, he fans her in the summer and warms her bed in the winter. But as soon as he wins her, he drops all "kindness" and gives her a flogging to "tame" her. "There need be no penalty for the husband who has killed his wife," he declares, showing that his behaviour is backed by the feudal legal system. These details in drawing the character of Chou Sheh reveal its ugliness with its social roots.

Kuan Han-ching's romances include such plays as *The Pond of Golden Thread*, *Girl in Disguise*, and *The Pavilion of Moon-Worship*. The main characters, all

women, seem to stand before us, weeping and sobbing, pouring out their sufferings. Though different in origin and conditions of life, their sex gives them a common fate in a feudal society. It is precisely because they are objects of humiliation and abuse that they win the author's deep sympathy.

### Master of Character

The creative genius of Kuan Han-ching is at its best in his drawing of character. His extant works depict people of every social stratum, and all come to life on the stage. No contemporary playwright created such a numerous and varied galaxy of types.

Kuan begins the description of each character by portraying his or her *milieu*. Conflicts and struggles are then developed, through which the features of the characters stand out as the main theme of the play proceeds. Sometimes he uses swift strokes of caricature. In *Snow in Midsummer*, for instance, when Chang Lu-erh drags Tou Ngo to trial, the prefect who sits as judge suddenly kneels down to the complainant. "All who start lawsuits," he says when his subordinates ask him why, "are my parents who supply me with food and clothing." This shows the cynical shamelessness of the corrupt officials.

High poetic imagination is also brought to bear to enrich the depiction. When Tou Ngo is about to be executed she prays to heaven that snow fall in June to a depth of three feet to cover the dead body of the innocently slain. This comes to pass. Tou Ngo's purity and strength emerge in this unforgettable image.

In the Chinese play, a mixture of singing and acting, poetic atmosphere makes more vivid the emotions of sorrow, happiness, parting and reunion. Kuan Han-ching was a master of the metaphorical and suggestive methods of traditional Chinese verse. In *The Pavilion of Moon-Worship*, for instance, when the mother and daughter flee from a calamity they suddenly find themselves buffeted by howling winds and pelting rain. The libretto runs: "They leave their home amidst wind and rain. They sigh with every step they make. Sad tears run down their cheeks. Every teardrop is matched by a raindrop, every sigh by the wind's wail."

Kuan's popular language gave liveliness and verve to his dialogues. In the lyric parts he freely employed the northern localisms of his day. But at the same time he used literary expressions from ancient Chinese poetry for colour and elegance. In his choice and use of words and expressions, he set an excellent example for later dramatists.

Kuan Han-ching's plays truly reflected the contemporary social conditions of his time. They conformed to the views and desires of the people at large. For this reason, as well as the realism and liveliness of the characters, his works, such as *Snow in Midsummer* and *Lord Kuan Goes to the Feast*, have not left the Chinese stage for seven centuries.

Since the liberation, some of Kuan's plays which had not been performed for a long time have been restaged. Translated into French, Japanese and English, many of his works have been acclaimed by readers abroad.



Illustration for *Rescued by a Coquette* from a 1616 A.D. Ming edition of plays of the Yuan dynasty

# CHINESE PRESS OPINION

people have strengthened their solidarity in the struggle against colonialism, and the United States has exploited the situation to undermine French interests there. On the other hand, France is on the verge of financial bankruptcy and the ruling

## Soviet-Arab Friendship

"The Chinese people are very happy to see friendly relations between the Soviet Union and the United Arab Republic grow. They place a high value on this friendship," declared *Renmin Ribao* editorially on May 17, commenting on President Nasser's visit to the Soviet Union and the May 15 U.S.S.R.-U.A.R. joint statement.

"The friendly relations between the Soviet Union and the United Arab Republic have a solid basis," the editorial notes. "As the joint statement affirmed, the two countries adhere strictly to the principles of peaceful co-existence among countries with different social systems and the Bandung spirit."

The paper says that U.S.S.R.-U.A.R. relations testify to the fact that the socialist countries and the nationally independent countries can co-exist peacefully, and support and co-operate with each other in the common struggle for world peace and against colonialism.

## The Fascist Menace in France

An extremely dangerous situation confronts France today, asserts an editorial on the front page of *Renmin Ribao* (May 23). The fascist forces have unleashed frenzied offensives both in Algeria and France to pave the way for a military dictatorship by de Gaulle. The outcome of the present sharp struggle will be decisive.

During the last war, the French people fought heroically against Hitlerite fascist rule. How did it happen that France is menaced by French fascism today, is the question *Renmin Ribao* asks in this editorial.

Tracing the background, it points out that since May 1947, when the Communists were ousted from the French Government, the French ruling circles adhered to the U.S.-led armaments drive and waged colonial warfare. As a result, France's international position has been declining steadily, its financial difficulties have mounted continuously and the living conditions of the people have deteriorated rapidly. Taking advantage of the chaotic situation in the country and the popular discontent resulting from it, the French fascist gang was able to extend its forces among a confused section of the people.

The French governments, formed by the middle-of-the-road parties, depended on the right wing, and even the extreme right, for support because of the anti-communist position of these parties. In effect this has played into the hands of the fascist forces and strengthened their influence in French politics.

The colonial war in Algeria has driven France into a blind alley, *Renmin Ribao* says. On the one hand, the North African

groups are fighting over the question of how to save the "French colonial empire" from collapse.

The fascist forces view this situation as a godsend. They have raised the banner of "national rejuvenation" to deceive the masses and keep the bourgeois centre parties as prisoners with threats of violence, so as to seize the reins of power in France.

The rise of the fascist forces, dangerous as it is, is not the only trend in the French political scene, the paper adds. Another major trend is the rapid growth of the working class and the progressive forces. Since the war, the French Communist Party has kept up its leading numerical position in the National Assembly. The French working class, despite all the obstructions of the right-wing leadership of the French Socialist Party, has greatly strengthened its solidarity and fighting spirit. This indicates that there exists in France today a powerful popular force capable of curbing and defeating fascism.

However, *Renmin Ribao* says, the fascist menace in France should not be underestimated. At present, the Pflimlin government is wavering and showing signs of weakness in the face of the fascist attacks. When Pflimlin requested investiture, he pledged that he would not submit to the anti-republican military rebellion. But he has not lived up to his promise. He permitted the arch-fascist de Gaulle to hold a press conference at which rebellion was openly instigated. At the same time, the French Communist Party and other progressive organizations were barred from holding anti-fascist demonstrations. Exclusion of the French Communist Party and failure to rely on

the popular forces make effective defence of the French Republican system impossible.

The only policy conforming with French national interests is one recognizing the right of national independence of the Algerian people and the establishment of Franco-Algerian relations on a basis of equality and mutual benefit, the editorial continues. But the Pflimlin government has not shown any intention to alter the repressive colonial policy in Algeria. And the fascist forces, while using the slogan of "national rejuvenation," are actually dragging France to still greater disaster. They hope to pursue an even more adventurist policy in Algeria. This could only lead to even more determined opposition from the North African people. The war would be extended, France would find herself in a worse situation and the possibility of improving relations with the North African people would be lost for ever.

There can be no future for fascism in France, *Renmin Ribao* concludes. De Gaulle will surely meet with an even more ignominious end than Hitler if he follows in the latter's footsteps. A world-shaking change has taken place since Hitler's time. In an era when the east wind prevails over the west wind, when the people's forces are overwhelmingly stronger than the forces of reaction, France's destiny is in the hands of the French people who have powerful forces at their disposal. In the present sharp struggle, the polarization of forces is very apparent. If the French bourgeois parties, the right-wing leadership of the French Socialist Party included, do not quickly change their policy and come to the side of the anti-fascist forces, they



France, on guard!

Cheng Wei in "Guangming Ribao"

will surely be discarded by the French people.

### Hands Off Indonesia!

Supporting the Chinese and Soviet government statements against U.S. intervention in Indonesia (see *Peking Review*, No. 12), *Renmin Ribao* declared editorially on May 17: "These are serious warnings to the American interventionists. The world can now see that China and the Soviet Union are resolved to oppose imperialist aggression and safeguard Asian and world peace."

"The U.S. imperialists," *Renmin Ribao* points out, "regard Indonesia as a 'power vacuum.' They feel that it is their inherent right to take the place of the Dutch colonialists and turn Indonesia into an American colony and base of aggression in Asia. . . . All the activities of the U.S. Government in Indonesia during the past years were directed at subversion and the overthrow of the Indonesian Government. Following the failure of the repeated coups d'etat, the United States turned to the creation and open support of the rebel 'government.'"

"Subversion-failure-subversion, this is the formula employed by the U.S. Government in Indonesia. Its persistent attempts to overthrow the Indonesian Government are motivated not only by the desire to divert the course of developments in Indonesia, but also to drag that country into the Western aggressive bloc and obstruct the advance of the surging national independence movements in Asia and Africa.

"This crude U.S. interference and aggression against Indonesia undermines the basic principles of international law and constitutes a threat to peace. The U.S. can in no way cover up its crime of intervention by using the Chiang Kai-shek clique to do its dirty work.

"At the same time, it is necessary to note that Philippine participation in such intervention violates the principles of the Bandung Conference and can bring no good to the Philippines."

"The U.S. imperialists have miscalculated in Indonesia," the editorial concludes. "They have underestimated the strength of the Indonesian people and the people all over the world. President Sukarno has warned the U.S. not to play with fire in Indonesia. Now the Chinese and Soviet peoples and other peoples of the Asian and African countries have warned the American imperialists. . . . If the United States persists in its intervention, it will reap what it sows."

### Kishi's Ambitions in Asia

Japanese Prime Minister Kishi is not only suppressing the progressive forces and strangling democratic freedom in Japan, but also harbours imperialist designs against other countries. He is

## THE PASSING SHOW

### He Came, He Talked, He Was Tomatoed!



"He has conducted himself effectively, efficiently, and with great dignity and has performed to the satisfaction, not only of us, but to our sister countries that he was sent to," said President Eisenhower at Washington airport, welcoming Vice-President Nixon back from his "good-will" tour of Latin American countries.



### In the Land of Plenty

"Since recession, customers (in the U.S.) have been stealing the supermarkets blind," *Time* magazine reports. Food stealing is on the increase. Cheese is hidden in distended bras, chops in hollowed-out books, packaged meat in false-bottomed market bags. At least \$250 million worth of goods is pilfered from supermarkets each year.

"Most chainstores have beefed up their security forces to catch their food stealing customers. Checkers learn catcherlike signals, (use) one-way mirrors, secret peepholes and closed-circuit TV to help spot the heisters."

Plenty of nothing is the recession's gift to plenty of unemployed.

attempting to rig up a "Northeast Asian Alliance" and revive the notorious "Greater East Asia Co-prosperity Sphere" to ride roughshod over the Asian peoples once again, warns an article in *Da Gong Bao* (May 21).

The "Northeast Asian Alliance" was first devised by the United States during the Korean War, the article recalls. Washington wanted to tie up Japan with the Syngman Rhee and Chiang Kai-shek cliques as part of a world-wide aggressive anti-communist chain. But because of the notoriety of the Syngman Rhee and Chiang Kai-shek cliques and of their inner contradictions, and particularly the firm oppositions of the Asian peoples, this plot couldn't be hatched.

Kishi, however, motivated by imperialist ambitions, is still trying to push this

conspiracy. Since Kishi's last visit to Taiwan, where he stressed "unity of the free world" with Chiang Kai-shek, his collusion with the Chiang clique has become more overt. At the same time, Kishi is making persistent efforts to curry favour with the Syngman Rhee clique. He waived Japan's claims to property in South Korea and sent many Korean residents in Japan to South Korea against their will.

The "Southeastern Asia Development Plan" which Kishi peddled during his Southeast Asia visits last year is really an attempt to revive the "Greater East Asia Co-prosperity Sphere" with American capital, Japanese technique and Southeast Asian resources. Kishi is clearly trying to tie the neutral countries in Asia to the war chariot of the United States.

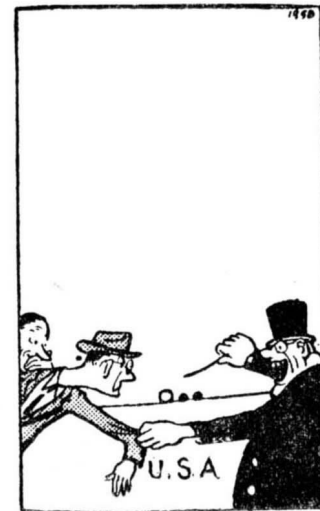

Man, if you want to see something. . . . . Take a look at this!  
Ying Tao in "Renmin Ribao"



# HEALTH & MEDICINE

## **More Medical Equipment Made in China**

China can now supply herself with all the general run of medical and surgical instruments and hospital equipment she needs. By the end of last year the total value of such goods made in the country was about four times as much as it was in 1952. Quite a fair selection of the medium range of medical equipment, including surgical instruments used in special departments and instruments used in diagnosis which require a relatively higher degree of skill to produce, can also be made in China. Some of the most advanced precision therapy units like Rontgen-ray apparatus and physical therapy units are also being produced here, and the rate of production is increasing, while the range of production in all grades is steadily expanding. Before liberation, of course, China depended almost entirely on imports for modern medical and surgical equipment.

The Second Five-Year Plan includes provisions for the manufacture of many new types of medical and surgical equipment so that by 1962 home industry will be able to supply all the needs of general hospitals. Among the new things to be made will be such advanced equipment as high milliamperage Rontgen-ray units, Rontgen-ray therapy units for deep and shallow radiation, supersonic therapy units, electro-encephalographs, instruments used in neuro-surgery, optical instruments for medical use, and therapy units used in gastrorrhaphy and arteriorrhaphy. During the Second Five-Year Plan China will be exporting medical instruments, supplies and equipment in general use.

## **New Medicine for Lowering Blood Pressure**

A species of *Rauwolfia* which grows in Yunnan Province has been found to be highly useful in lowering blood pressure. Experiments carried out on animals prove that its efficacy compares favourably with that of *Rauwolfia serpentina* found in India (source of the chief ingredient of the Indian medicine Serpina) which has hitherto been considered the best remedy against high blood pressure. Injected into rabbits, at its maximum efficacy, the drug obtained from this

plant lowers blood pressure by 50 per cent; at average efficacy it reduces pressure by 15 to 25 per cent and is effective for from 70 minutes up to 4 hours. It is only slightly toxic.

Investigations conducted by the Research Institute of Chinese Medicine in Yunnan shows that the Chinese *Rauwolfia* grows in thirteen places in the province; three to four kilogrammes of it can be reaped per square kilometre in places with the highest yield.

## **Therapeutic Serum Made from Animal Blood**

Thanks to the efforts of Hsieh Yu-chin, chief technician of the Wuhan Research Institute of Biological Products, and his assistants, therapeutic serum has been successfully made in China by using animal instead of human blood. Only a few countries so far make this form of serum.

Therapeutic serum is much used in first aid to patients who have lost excessive blood from wounds or other causes. It is a most effective means of increasing the blood's protein content. In the past all therapeutic serum used in China was made from human blood and this made it relatively scarce and costly. Animal blood serum can, of course, be manufactured in quantity; its price is only 1 per cent of that made from human blood.

Clinical tests prove that the new Chinese serum has a high degree of efficacy. Professor I.G. Kochergin, a prominent Soviet specialist assisting the Ministry of Public Health, has studied it and rates it in quality as being fully up to international standards.

## **Test on New T.B. Remedy**

Experiments carried out by the No. 2 Hangchow Municipal Hospital show that essence of *huang lien* (*Coptis japonica*) is efficacious in treating lung tuberculosis. The hospital began its experiments in August 1957. Over a period of over six months ten patients suffering from tuberculosis were given oral doses of a syrup made from *huang pai* (*Phellodendron amurense*), which is rich in essence of *huang lien*. Six of these ten patients had never used any anti-tuberculosis medicaments before while the remaining four had been treated for a long time with various other kinds of anti-T.B. preparations but had failed to recover. At the end of seven months, it was found that the affected lungs of the first six patients had improved in one way or another by 80 per cent and the other four patients had entirely recovered. Further experiments are continuing.

*Huang lien* is one of the most commonly used medical substances in China. It has a very strong antibiotic action. Quite a number of Chinese hospitals have been using *huang lien*

recently to cure suppurative infections, dysentery, and diarrhoea but it has seldom been used hitherto for treating tuberculosis.

Essence of *huang lien* can also be obtained from *kuo shan lung* (*Dioscorea sp.*) which is also found in many parts of China.

## **Successful Operation on Heart**

A patient suffering from congenital heart disease has been saved by an operation on the heart under direct observation. This operation, the first of its kind in China, was carried out by surgeons of the Chungshan Hospital of the Shanghai First Medical College.

The patient, a 21-year-old student, had an abnormal blood circulation resulting from a perforation in the interauricular septum. From the age of fifteen he suffered from palpitations and shortage of breath. Lately his condition worsened and he could not eat or sleep normally.

This defect of the interauricular septum used to be incurable. Only in the past four or five years have modern surgeons learnt to operate on and repair a heart so damaged. Thanks to the fact that the surgeons of Chungshan Hospital have practised the operation on animals over the past two years, they were ready when on April 10 it was decided that this operation offered the only hope of saving the patient. With the patient under hypothermal anaesthesia, they cut open the heart and sutured the hole in the interauricular septum in about 7 minutes. The whole operation took under three hours.

The patient's heart has shown a clear turn for the better; his blood pressure and pulse are normal.

## **New Cancer Hospital**

A new cancer hospital, first of its kind here to use cobalt 60 for cancer treatment, has been set up in Peking. Founded by the Chinese Academy of Medical Sciences, it can give medical, surgical, radium and radiation therapies to cancer patients.

It has a gamatron (a "cobalt 60 bomb") and other equipment presented by the Soviet Union, 150 beds and an out-patient department to handle up to 200 patients daily. It also has facilities for research.

## **Concentrated Sunlight to Cure Skin Diseases**

A Shanghai factory has produced China's first apparatus to use solar energy for curative purposes. Its 210 reflectors focus sunlight into a single beam which can then be directed into the waiting room for the patient. Sunlight is good for skin tuberculosis, lupus erythematosus, white ringworm, erysipelas, and myositis.

# CHINA AND THE WORLD

## Burmese Speakers Here

Sao Shwe Thaike, Speaker of the Burmese Chamber of Nationalities, and Bo Mu Aung, Speaker of the Chamber of Deputies, are making a short visit to China. While in Peking, they were received by Liu Shao-chi, Chairman of the Standing Committee of the National People's Congress.

## Good Business in Canton

Over £64 million sterling worth of business was transacted at the Canton Commodities Fair which ended this month. This was ten times as much as at the 1957 Spring Fair, and twice the 1957 Autumn Fair figure.

Many industrial products which China only recently began to produce were displayed and sold at the fair. These included complete sets of machinery for cotton spinning mills and paper mills, machine tools, lorries and semi-conductor radios. Deals in various types of machine tools increased eightfold in value compared with the last fair.

Chinese trade organizations, on their part, placed many orders with British, French, West German and Dutch business

men. Their purchases included metal products, rolled steel, chemical fertilizer, artificial fibres, wool tops, dyes, instruments, pharmaceuticals and medical apparatus. An order for 11,000 tons of steel boiler plates was placed by the China National Metals Import Corporation with the West German firm Ernst Komrowski and Company.

The fair, which lasted a month, was visited by representatives from more than a thousand foreign commercial firms in forty-four countries.

## TRADE NEWS

Trade worth 25 million rupees each way will be transacted between China and India in the six months from May to October, according to an agreement between the Chinese and Indian state trading companies. Indian cotton, pepper and tobacco will be exchanged for Chinese caustic soda, soda ash, newsprint, calcium carbide and other industrial raw materials.

The volume of trade is expected to be doubled in the six months after October.

A Chinese technical group has just completed a tour in West Germany. It attended the Hanover Fair and visited various industrial enterprises.

Another Chinese trade group is now in Australia to negotiate for greater reciprocal trade. It is attending wool auctions and plans to sell Chinese products such as silks, textiles, tea, chemicals, minerals and handicrafts. It will visit New Zealand later.

## Briefs

**The German-Chinese Society** of West Germany, whose annual conference was recently held in Dortmund, is enrolling more and more members of the Bundestag.

Professor Ernst Meyer (Social Democrat M.P.) and Peter Nellen (Christian Democrat M.P.) were elected members of the society's executive council, while Dr. Thomas Dehler, former Minister of Justice, and Wolfgang Stammberger (both Free Democrat M.P.s) became members of the advisory board. Vice-President of the Bundestag Professor Carlo Schmid also joined.

The society's call for normalization of relations with China is steadily gaining support in political circles, the chairman of the society Dr. Wolf Schenke told the Hsinhua correspondent in Berlin. He also announced that the society would establish regional branches in major West German cities and arrange for an exchange of trade and cultural delegations with China this year.

**A Polish-Chinese Friendship Society** was formed in Warsaw on May 17. In a speech at the inaugural meeting, S. Jedrychowski, Member of the Political Bureau of the Central Committee of the Polish United Workers' Party, said that the society was born of the growing desire of many sections of the Polish people to become better acquainted with China and forge close ties between the two countries.

I. Loga-Sowinski, President of the Central Council of Polish Trade Unions, and P. Yaroszewicz, Vice-Chairman of

## Moscow Symphony in Peking

The concerts of the State Symphony Orchestra of the U.S.S.R. in Peking are an eagerly awaited event in New China's musical life. Tickets for the performances were snapped up within a few hours of going on sale.

With her own young symphony orchestra and recitals by not infrequent musical visitors, Peking, as any day's radio programme shows, is no longer the symphonic backwater it was eight years ago. But this is the first time it has welcomed a full symphony orchestra of over a hundred musicians with two such outstanding conductors as Konstantin Ivanov, its art director, and Professor Nikolai Anosov. Soloists Victor Pikaizen (violin) and young Dmitry Bashkirov, prize-winner at the Marguerita Long pianoforte competitions in Paris also came with the orchestra.

The opening night on May 18 saw the first performance in Peking of Shostakovich's "1905" Symphony, No. 11, short compositions by Sitson Ma and Ho Lu-ting and Tchaikovsky's triumphant "1812 Overture."

The Shostakovich symphony lived up to expectations. It is in the great tradition of music that is at once rich in feeling and thought, with the clarity that comes of masterly craftsmanship and completeness of artistic conception. Written in commemoration of the fortieth anniversary of the Great October Socialist Revolution, it was awarded a Lenin prize this year. It is in four movements based on the theme of the first Russian revolution of 1905. In a sense, it is "programme" music, but it is not in the imitative terms of ordinary programme music. Shostakovich paints his huge canvas in musical terms, calling up rich associations of sound, mustering his effects with superlative dramatic skill.

It was the Soviet State Symphony Orchestra that gave the Eleventh its first performance in Moscow. In Peking, conducted by Ivanov, it gave a rendering that brought out every nuance of phrasing and projected the whole immense conception with insight and comprehensiveness.

The audience enjoyed a sparkling performance of Sitson Ma's nostalgic lyric, variations on a Mongolian folk song, and Ho Lu-ting's "Soirée," a vivacious little piece that has long been a favourite in China. It has a Chinese colour achieved not only by its melodies and harmonies but in its use of actual Chinese drums as part of the orchestra. Ho Lu-ting was in the audience and insistent applause brought him on stage in a standing ovation with the orchestra and its conductor.

The second performance of the Soviet orchestra featured Tikhon Khrennikov's First Symphony, Shih Yung-kang's symphonic poem "Legend of the Yellow Crane" and Tchaikovsky's "Pathétique", all conducted by Professor Anosov.

A polished performance was given to Shih Yung-kang's imaginative "Legend." It is based on the Chinese folk-tale of the magic crane that used to amuse the people of a village until it was snatched away by a greedy official. It refused to dance for this would-be monopolist, and when its real master, a musician, returned, promptly flew away back to the people. It is an allegory of the art that must return to the people from whom it comes and from whom the rich exploiters would steal it.

The State Symphony Orchestra, already a hit in Peking, will visit Tientsin, Shanghai and Harbin later.

the Council of Ministers, were among the forty-five elected to the society's council. Seventeen local branches have already been set up in various parts of Poland.

**The Chinese author Sun Yung** has been awarded the Order of Labour by the Hungarian Government for his outstanding services in translating the works of Sandor Petofi and other Hungarian writers into Chinese.

Sun Yung and the Chinese poet Kung Mu are now visiting Hungary. While in Budapest they presented the Hungarian Writers' Union with many volumes of Chinese translations of Hungarian literature.

**The Chinese People's Volunteers** are helping the Korean people build two big reservoirs. Thousands of C.P.V. officers and men are now working on the dams. They plan to complete them in three months' time, before they withdraw to China this year, instead of in the three years originally planned by the Korean Government. The Jungjoo Reservoir, with a 373-metre-long dam, will irrigate 3,000 hectares of land; while that at Koksan will have a storage capacity of nearly 1,200,000 cubic metres.

**The Kite**, the first movie jointly produced by the Chinese and French film industries, had a very successful pre-

miere at the Cannes International Film Festival in France.

A story of the adventures of a French boy and his sister in China, it was co-directed by Roger Pigaut and Wang Chia-yi. French and Chinese child actors took part. It was filmed both in Peking and Paris.

The film is scheduled for public release in France in September.

#### Visitors

A delegation of the Moscow City Soviet led by N.I. Bobrovnikov.

An Indian Congress Youth Delegation led by R. Varma, Chairman of the Youth Department of the Congress Committee.

## WHAT'S ON IN PEKING

### — Highlights of Current Entertainment, Exhibitions, etc. —

Programmes are subject to change. Where times are not listed consult theatre or daily press.

#### PEKING OPERA

▲ **YANG NGO** The story of a patriotic Ming dynasty woman who led the people in resisting foreign invaders. A new historical Peking opera produced by the Fourth Troupe of the Peking Opera Company of Peking. Starring Wu Su-chiu and Chiang Tieh-lin.

May 27 Changan Theatre  
May 30 Chi Hsiang Theatre

#### THEATRE

▲ **THE RED STORM** A play about the great "February 7" railway workers' strike in 1923. Produced by the China Youth Art Theatre and directed by Chin Shan.

May 27-June 2 China Youth Art Theatre

▲ **THE CAPTURE OF THE WEI HU MOUNTAIN** Dramatic adaptation of Chu Po's new novel *In the Snowy Forest*. A PLA man in disguise succeeds in becoming the confidant of the Hawk, a notorious bandit, and finally brings about his capture. Produced by the Peking People's Art Theatre.

May 27-31 Capital Theatre

▲ **A SISTER'S LOVE (Tang Ti Chih Hua)** A historical play written by Kuo Mo-jo about the Warring States Period. A young man from the State of Chi who advocates the aligning of the six states against the powerful State of Chin, helps to assassinate the leaders of the pro-Chin faction and then commits suicide. In order not to involve his sister, he first destroys all evidence of his identity. His sister, nevertheless, publicly identifies the body and proclaims his heroic deed, and then she too takes her own life. Produced by the Experimental Theatre of the Central Drama School.

May 26-28 Peking Workers' Club  
May 29 People's Theatre

#### MODERN OPERA

▲ **MADAM BUTTERFLY** Puccini's famous opera in Chinese. New production by the Central Experimental Opera Theatre. Cheng Hsin-li and Li Chin-wei in the role of Cho-Cho-San.

(The opening date, originally announced as May 25 in our last issue, has been postponed to June 1.)

At Tienchiao Theatre

#### FOLK OPERA

▲ **WHITE LOTUS**—The story of a fairy who falls in love with a young forester and their struggle against the feudal forces which oppose their marriage. It ends happily. Produced by the Folk Opera Ensemble from Huhehot, Inner Mongolia.

May 28 Chi Hsiang Theatre

#### PUPPET THEATRE

\* **THE DRAGON**—adapted from a Szechuan folk-tale. A poor peasant lad is transformed into a powerful dragon in order to kill the wicked landlord who oppresses the people.

\* **BIG IVAN**—written by world-famous Soviet puppet-master Sergei Obraztsov. How hard-working, kind-hearted Ivan wins through despite the tricks and wiles of his lazy and envious brothers.

\* **MISTRESS CLEVER**

\* **THE LITTLE COTTAGE ON THE HILL**

\* **LITTLE SHEPHERD**

\* **PIGSY**

Produced by the China Puppet Art Theatre.

Some of these plays will be on the programmes of:

May 28 & June 1, Working People's Palace of Culture

May 30 Cultural Club of the Sino-Soviet Friendship Association

May 31 Chungshan Park

#### CONCERTS

The visiting STATE SYMPHONY ORCHESTRA OF THE U.S.S.R.

Programme listings (tentative) for the following dates:

MAY 28

TCHAIKOVSKY—Symphony No. 5 in E Minor

TCHAIKOVSKY—Concerto for Violin and Orchestra in D Major

KHATCHATURIAN—Excerpts from the ballet "Gayaneh"

Conductor: K. Ivanov

Soloist: V. Pikaizen

MAY 30

FRANCK—Symphony in D Minor

RACHMANINOFF—Concerto No. 2 for Piano and Orchestra in C Minor

TCHAIKOVSKY—Concerto for Violin and Orchestra in D Major

TCHAIKOVSKY—"Francesca da Rimini,"

Fantasia for Orchestra

Conductor: Li Teh-lun

MAY 31

(Joint performance with the Chinese Central Philharmonic Symphony Orchestra)

BEETHOVEN—Overture to "Egmont"

TCHAIKOVSKY—Fourth movement from

Symphony No. 5 in E Minor and third

movement from Symphony No. 6 in

B Minor

GLINKA—Overture to "Russlan and

Ludmilla"

KHATCHATURIAN—Waltz from the

music to Lermontov's "Masquerade"

SITSON MA—"A Nostalgic Song"

HO LU-TING—"Soirée"

LIU TIEH-SHAN and MAO YUAN—

"Dance of the Yao People"

Conductors: M. Anosov

K. Ivanov

Li Teh-lun

Chang Ning-ho

#### FILMS

▲ **A HERDSMAN'S SON COMES HOME** A former PLA serviceman leads the fight to build a much-needed water conservancy project in an Inner Mongolian village. Produced by the Changchun Film Studio.

May 29-June 2 Children's Cinema, Kwangho Theatre

▲ **THE MAGIC STICK** A delightful coloured fairy-tale for children from Czechoslovakia. A too-trusting musician is cheated of his food-producing magic table-cloth and gold-giving donkey by a cunning inn-keeper. A fairy gives him a third treasure, the Magic Stick, with which he gives the inn-keeper his deserts and regains his treasures.

June 1 & 2 Hsin Chung Kuo, Kwangho Theatre

#### EXHIBITIONS

▲ **EXHIBITION OF WU CHANG-SHIH PAINTINGS**—some of the finest works by this late distinguished painter of the traditional Chinese school. Sponsored by the "Peace" Paintings Studio, daily 10 a.m.—9 p.m. till June 5.

At 92 Wang Fu Ching Street

▲ **PALACE MUSEUM** Art Gallery Over 300 traditional Chinese paintings of the Ming and Ching dynasties.

Pottery and Porcelain Exhibition Rooms Exquisite works of art ranging in time from the primitive society in China up to the end of the Ching dynasty.

Open daily 8 a.m.—5 p.m.

#### VARIETY EVENING

▲ Join the "Summer Garden Party" of the working people of Peking at the Working People's Palace of Culture.

For 15 cents you can see any of the following:

\* **THE DRAGON**—puppet play by the China Puppet Art Theatre

\* **THE CUCKOOS ARE SINGING AGAIN**—pingchu opera by the Experimental Ping-chu Opera Company of Peking

\* **WU SUNG**—Peking opera by the Lien Yi Peking Opera Company

\* **LIU CHIEH-MEI**—chu yi play by the Peking Chu Yi Troupe

\* **HAPPINESS**—Chinese feature film

\* **CONJURING AND ACROBATICS**—SHADOW THEATRE PLAYS—BALL GAMES

—CHESS MATCHES—HSIANG SHENG (comic dialogue)

May 30 at 7:30 p.m.

#### WHAT'S ON IN THE PARKS

A tradition in New China—Take your kiddies to the parks on June 1—Children's Day For children

\* Free admission

\* Free boat-rides

\* Free entertainment and LOTS OF GAMES!



NEWLY PUBLISHED



## THE CAT

by Wang Meng-pai

### A YUNG PAO CHAI PRINT

The late Wang Yun, styled Meng-pai, was a former professor of the Peking Art Academy, and one of the best known contemporary painters in the classical Chinese style. His work has a vitality, freshness and immediacy of perception that delights the eye.

*The Cat* shows the artist at his best. It sits calmly on the grass but the artist has caught that barely perceptible inclination of its head that shows it to be looking curiously at something in the distance as if a surprise were in store at any moment. It is drawn in Chinese ink and executed with the utmost delicacy and economy of strokes.

Reproductions of this painting by the Yung Pao Chai art studio of Peking are made with woodblocks, and printed on the same paper and with the same ink as the original. So skilfully are they done that it is hard to believe that they are not original paintings. This is a limited edition mounted on silk scrolls ready for hanging. The picture measures 73 × 44.5 cm., the actual size of the original.

Reproduced by:

**YUNG PAO CHAI STUDIO**

86 Hsi Liu Li Chang . . . . . Peking

Distributed by:

**GUOZI SHUDIAN**

38 Suchou Hutung . . . . . Peking

*We export:*

VEGETABLES, FRUITS, AQUATIC PRODUCTS,  
WINE AND OTHER FOODSTUFFS



**CHINA NATIONAL FOODSTUFFS EXPORT  
CORPORATION**

Tientsin Vegetables, Fruits & Aquatic Products Branch  
33 Yingkow Road, Tientsin, China  
Cable Address: FOODFIRST TIENSIN

*We supply*

**HOT ROLLED STEEL  
BARS & SECTIONS**

High Quality

Reasonable Prices

*Enquiries welcomed*

*Prompt attention!*

**CHINA NATIONAL METALS IMPORT CORPORATION**

(Import & Export)

Erh Li Kou, Hsichiao, Peking, China Cable Address: CHIMETALS PEKING

# Shuttle Change Automatic Towel Loom

For weaving  
Terry & Jacquard  
**TOWELS**

**LOOM  
TYPE  
1511B**

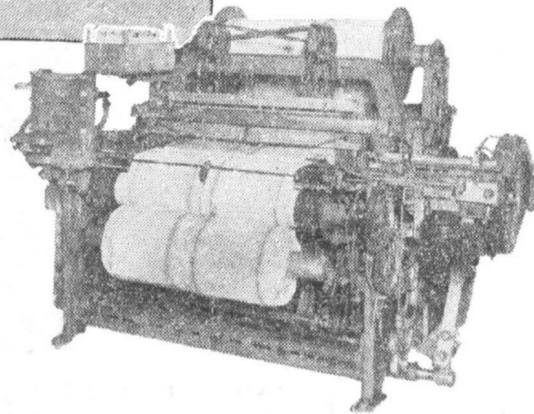

## SPECIFICATIONS :

Reed space: 42"  
Cloth width: 33"  
Shuttle magazine  
capacity: 10 shuttles  
Diameter of warp  
beam flange: 18"  
Diameter of warp  
beam: 4 $\frac{3}{8}$ "  
Distance between warp  
beam flanges: 35"  
Power required:  $\frac{3}{4}$  h.p.  
Number of picks per cm.:  
12-15 picks  
(24 - 80 teeth change gears  
can be supplied upon request)

**INCREASE production at lower costs  
with our reliable and sturdy LOOMS**

### **EASY OPERATION**

A new hand can easily be trained to operate the loom because of its simple construction, easy adjustment, interchangeable and standardized parts plus many modern automatic devices.

### **LABOUR SAVING**

One weaver can attend 16-32 looms or more.

### **HIGH WORKING EFFICIENCY**

Automatic controls guarantee working efficiency above 97%.

### **HIGH OPERATION SPEED**

The economical speed is 180 r.p.m.!

### **HIGH PRODUCTION**

High operation speed plus high working efficiency ensure high production.

### **LONG SERVICE LIFE**

### and **LOW MAINTENANCE COST**

Robust construction, minimum vibration, selected materials, high quality workmanship and accurate finishing reduce the wear and tear and prolong the life of the loom.

**TRIAL ORDERS WELCOMED**

*For further particulars or descriptive material please write to.*

**CHINA NATIONAL TRANSPORT MACHINERY IMPORT CORPORATION**

*(Import and Export)*

Head Office: Erh Li Kou, Hsichiao, Peking - - - - - Cable Address: TRANSMACH PEKING  
Shanghai Branch: 27 Chung Shan Road, E1, Shanghai - - - - - Cable Address: TRANSMACH SHANGHAI  
Hongkong Agent: China Resources Company, Bnk of China Building, Hongkong - Cable Address: CIRECO HONGKONG

# Order PEKING REVIEW from:

(A Partial List of Our Dealers)

<b>Argentina</b>	Norberto O. Martinez, Av. Olivera 1556, Buenos Aires	Lok-Milap, District Court Road, Bhavnagar, Saurashtra
<b>Australia</b>	A. Keesing, Box No. 4886, G.P.O., Sydney, N.S.W.	People's Book House, Opp. Jaganmohan Palace, Mysore
<b>Austria</b>	Gerold & Co., Wien 1, Graben Globus-Buchvertrieb, Salzgies 16, Wien 1	Vijay Stores, near Gopal Talkies, Station Road, Anand
<b>Belgium</b>	Mertens & Stappaerts, Oudaan 28, Antwerpen Du Monde Entier, 5 Place St-Jean, Bruxelles Librairie Romain Rolland, Place des Carmes, 12, Liège	New Century Book House, C-17, Majestic Circle, Bangalore-9
<b>Brazil</b>	Editorial Vitoria Ltda., Rua Juan Pablo Duarte, 50-Sobrado, Rio de Janeiro	People's Book Stall, B. H. U. Gate, Banaras-5 People's Book House, 278/79, Narayan Peth, Laxmi Road, Poona-2
<b>Burma</b>	The People Daily, 84th Street, Letsaigan Mandalay Nan Chio Book Supplier, 178 Fraser Street, Rangoon People's Literature Committee and House, 546 Merchant Street, Rangoon The International Publishing House, No. 11, South Moat, Sule Pagoda, Rangoon Kyaw Linn Book Sellers and Publishers, 180, 51st Street, Rangoon	People's Book House, Grand Hotel Building, Frazer Road, Patna-1 People's Book House, 7, Bisheshwar Nath Road, Lucknow
<b>Canada</b>	Progress Subscription Service, 924 King Street, West Toronto, Ontario People's Co-operative Bookstore Association, 337 West Pender Street, Vancouver, B.C.	<b>Indonesia</b> Firma "Rada", Pintu Besar Selatan 3A, Djakarta-Kota O. K. Sports & Co., Ltd., 214 Djalan Gadjah Mada, Djakarta-Kota
<b>Ceylon</b>	G. Ranasinghe, Regent Building, 4, Parsons Road, Colombo People's Publishing House, 249, 1st Division, Maradama Colombo-10	<b>Italy</b> Libreria Mario Vigna, Via Zanelli 2, Faenza Editori Distributori Associati, Via Andegari 6, Milano MM Santo Vanasia, 71, Via Mauro Macchi, Milano Libreria Rinascita, Via delle Botteghe Oscure 1-2, Roma
<b>Denmark</b>	Land og Folks Boghandel A/S, Bredgade 37, Kobenhavn, K	<b>Japan</b> Far Eastern Book-Sellers, Kanda P. O. Box No. 72, Tokyo Daian Cultural Trading Co., Ltd. 2-11, Kanda-Sarugaku-cho Chiyodaku, Tokyo Nauka Ltd. No. 2, Kanda-Jinbocho, Chiyodaku, Tokyo
<b>England</b>	Central Books Ltd., 37 Grays Inn Road, London, W.C.1. Collet's Holdings Ltd., 45 Museum Street, London, W.C.1. Wm. Dawson & Sons Ltd., Cannon House, Macklin Street, London, W.C.1.	<b>Lebanon</b> Maison d'Edition et de Diffusion Dar El Farabi, B. P. 3181, Beyrouth
<b>Finland</b>	Kansankulttuuri Oy, Simonkatu 8, Helsinki Rautatiekirjakauppa, Koydenpa uno jankatu 2, Helsinki	<b>Mauritius</b> New Youth Book Club, 34, Jumma Mosque, Port Louis
<b>France</b>	Librairie du Globe, 21 rue des Carmes, Paris Ve Maison du Livre Etranger, 9 rue de l'Eperon, Paris Vie Les Livres Etrangers, 10, rue Armand-Moisant, Paris 15e Presses Universitaires de France, Librairie Internationale, 17 rue Soufflot, Paris Ve	<b>Mexico</b> Fondo de Cultura Popular. A. C., Av. Hidalgo 75, Despacho 107 (Apartado Postal 2352), Mexico (1), D. F. Editora y Distribuidora Nacional de Publicaciones, S. R. L. G. Obregon No. 17, Apartado No. 13709, México (1), D. F.
<b>German Federal Republic</b>	Brucken-Verlag GMBH Dusseldorf 1, Franklinstr. 38 KAWE, Berlin-Charlottenburg 2, Joachimsthalerstrasse Kubon & Sagner, Inh. Otto Sagner, (13a) Furth im Wald, Schliessfach 64 Santo Vanasia GMBH, Streitzuggasse 7, Koln W. E. Saabach, GEMH, Gerconstrasse 25-29, Koln Presse-Vertriebs-Gesellschaft, Frankfurt A.M. Mainzer Landstr. 225-227	<b>New Zealand</b> The Progressive Book Society Ltd., 14-16 Darby Street, Auckland C.1. Modern Books, 48A Manners St., Wellington
<b>Hongkong</b>	Sin Min Chu Publishing Co., 175, Queen's Road, Central Life Reader Sinzh Joint Publishing Co., 54, Queen's Road, Central	<b>Norway</b> A/S Bokjhorner, Stortingsplass 7, Oslo John Grundt Tanum, Tidligere Aschehougs Boghandel, Karl Johans Gate 43, Oslo
<b>Holland</b>	Boekhandel "Pegasus", Leidsestraat 25, Amsterdam-C Meulenhoff & Co. N.V., P.O. Box 197, Amsterdam-C	<b>Pakistan</b> Pakistan China Friendship League, Model Town, Lahore, West Pakistan
<b>Iceland</b>	Kaupfelag Reykjavikur og Nagrennis, Skolavordustig 12, Reykjavik	<b>Sudan</b> Al Mowatin Bookshop, P. O. Box 1130, Khartoum
<b>India</b>	Bhawnani & Sons, 8-F Block, Connaught Place, New Delhi People's Publishing House (Private) Ltd., 5, Jhandewalan Estate, M.M. Road, New Delhi The Popular Book Depot, Lamington Road, Bombay-7 P.P.H. Bookstall, 421, Sandhurst Road, Bombay-4 Oxford Book & Stationery Co., 17, Park Street, Calcutta-16 National Book Agency Ltd., 12, Bankim Chatterjee Street, Calcutta-12 Kamalalaya Stores Ltd., 156A, Dharamatala Street, Calcutta-13 Swadesamitran (Book Dept.), Victory House, Mount Road, Madras New Century Book House, 199, Mount Road, Madras-2	<b>Sweden</b> Almqvist & Wiksell Bokhandel AB, Gamla Brogatan 26, Stockholm C Forlagsaktiebolaget Arbetarkultur, Kungsgatan 84, Stockholm Gleerupska Universitets Bokhandel, Lund Gumperts Aktie Bolag, Sodra Hamngatan 35, Goteborg
		<b>Switzerland</b> Genossenschaft Literaturvertrieb, Feldstrasse 46, Zurich 4 La Librairie Nouvelle, 18 rue de Carouge, Genève Librairie Rousseau, 36 rue JJ Rousseau, Genève Pinkus & Co., Limmatbuchhandlung, Froschaugasse 7, Zurich 1
		<b>Trieste</b> Libreria Internazionale, Licinio Cappelli, Corso, 12
		<b>Uruguay</b> Ediciones Pueblos Unidos Ltda., Colonia y Tacuarembó, Casilla Correo 589, Montevideo
		<b>United Arab Republic</b> Al Gomhouria Distributing Co., 37, Sh. Kasr El Nil, Cairo The National Publishing & Distributing Co., 5, Sh. Doubreh, Cairo Librairie El Salam, 43 Rue Zaghoul, Alexandria Omar Ponbakji, Rue Saab Allah, Bjabri, Damascus (Papyrus) Dar El-Yakaza El-Arabiya, Moutanabby St., Damascus
		<b>U.S.A.</b> Imported Publications and Products, 4 West 16th Street, New York 11, N.Y.

## ANNUAL SUBSCRIPTION RATES

(air postage included)

Australia	A£	24/-
United Arab Republic	pias.	100
India, Ceylon, Pakistan	Rs	12.00
Indonesia	Rp	100
Japan	Yen	1,400
Middle & Near East	£	24/-
Latin American countries	\$	6.00
U.K. & other sterling countries	£	24/-
U.S.A., Canada	\$	8.00

General Distributor:

GUOZI SHUDIAN

P. O. Box 399, Peking, China



# Free to Subscribers of PEKING REVIEW

The 8 books listed below are yours to choose from. One copy of any book will be given FREE to all who take out a year's subscription to PEKING REVIEW during our free-book subscription campaign which will last from June to July.



## THE PLAINS ARE ABLAZE

by Hsu Kuang-yao

A true and intimate story of guerrilla warfare during the War of Resistance to Japanese Aggression.

278 pp. Illustrated.

## YO BANFA!

by Rewi Alley

Extracts from the diary of the famous New Zealand writer, in which he draws on his own experience to contrast the happenings of today with those of yesterday.

216 pp. With a foreword by Joseph Needham, F.R.S.



## CHANGES IN LI VILLAGE

by Chao Shu-li

The happenings in a Shansi village during the War of Resistance to Japanese Aggression, told in a style that is the author's own.

224 pp.

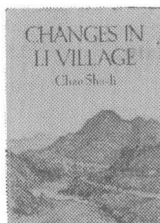

## THE PEOPLE HAVE STRENGTH

by Rewi Alley

A sequel to *Yo Banfa!*, spotlighting the human factors behind the great changes taking place in China today.

282 pp.

## First Five-Year Plan for Development of the National Economy of the People's Republic of China in 1953-1957

232 pp.



## HANDBOOK ON PEOPLE'S CHINA

Essential facts and figures about New China.

"Just the things I want to find in a handbook..."

—P.A. *Labour Monthly*

236 pp.

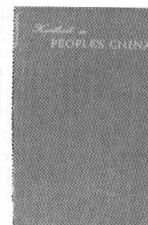

## WATER CONSERVANCY IN NEW CHINA (an album)

A record of how New China's water conservancy achievements bring the Chinese people more agricultural products and thereby better their living conditions.

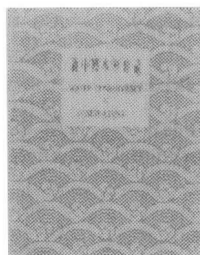

## HAPPY YOUTH OF CHINA (an album)

Since liberation Chinese youth have taken a rightful place in their country. This album presents vivid scenes of Chinese youth in various fields.

## SUBSCRIBE NOW TO BE SURE YOU GET YOUR CHOICE

ALL YOU HAVE TO DO is choose your book and fill in the form below (or a copy) and post it together with your subscription fee to our dealers (see inside back cover). If your title is out of stock you will be asked to choose again.

### FREE BOOK & SUBSCRIPTION FORM

TO: .....

Please send me FREE .....  
(Insert name of one book from the above list)

I enclose ..... for a year's subscription to PEKING REVIEW  
(See inside back cover for rates)

starting from ..... 1958

My Name .....

My Address .....

(Please use block letters)

General Distributor:

**GUOZI SHUDIAN**

P. O. Box 399

Peking, China